

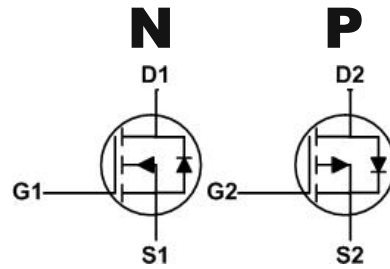

- ★ 100% EAS Guaranteed
- ★ Green Device Available
- ★ Super Low Gate Charge
- ★ Excellent CdV/dt effect decline
- ★ Advanced high cell density Trench technology

### Description

The WLQ30G20D is the high performance complementary N-ch and P-ch MOSFETs with high cell density, which provide excellent RDSON and gate charge for most of the synchronous buck converter applications . The WLQ30G20D meet the RoHS and Green Product requirement 100% EAS guaranteed with full function reliability approved.



### PDFN3333-8L Pin Configuration

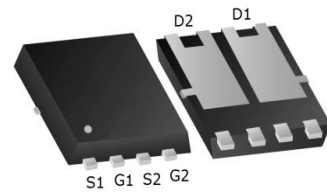

### Product Summary

| BVDSS | RDSON | ID   |
|-------|-------|------|
| 30V   | 14 mΩ | 16A  |
| -30V  | 25 mΩ | -14A |

### Absolute Maximum Ratings

| Symbol                | Parameter                                  | Rating     |            | Units      |
|-----------------------|--|------------|------------|------------|
|                       |  | N-Ch       | P-Ch       |            |
| $V_{DS}$              | Drain-Source Voltage                       | 30         | -30        | V          |
| $V_{GS}$              | Gate-Source Voltage                        | $\pm 20$   | $\pm 20$   | V          |
| $I_D@T_C=25^\circ C$  | Continuous Drain Current, $V_{GS} @ 10V^1$ | 16         | -14        | A          |
| $I_D@T_C=100^\circ C$ | Continuous Drain Current, $V_{GS} @ 10V^1$ | 5          | -4         | A          |
| $I_D@T_A=25^\circ C$  | Continuous Drain Current, $V_{GS} @ 10V^1$ | 2.3        | -1.8       | A          |
| $I_D@T_A=70^\circ C$  | Continuous Drain Current, $V_{GS} @ 10V^1$ | 1.8        | -1.5       | A          |
| $I_{DM}$              | Pulsed Drain Current <sup>2</sup>          | 40         | -40        | A          |
| EAS                   | Single Pulse Avalanche Energy <sup>3</sup> | 26.6       | 110        | mJ         |
| $I_{AS}$              | Avalanche Current                          | 8.7        | -20        | A          |
| $P_D@T_C=25^\circ C$  | Total Power Dissipation <sup>4</sup>       | 10.8       | 10.8       | W          |
| $P_D@T_A=25^\circ C$  | Total Power Dissipation <sup>4</sup>       | 2          | 2          | W          |
| $T_{STG}$             | Storage Temperature Range                  | -55 to 150 | -55 to 150 | $^\circ C$ |
| $T_J$                 | Operating Junction Temperature Range       | -55 to 150 | -55 to 150 | $^\circ C$ |

### Thermal Data

| Symbol          | Parameter  | Typ. | Max. | Unit         |
|-----------------|--|------|------|--------------|
| $R_{\theta JA}$ | Thermal Resistance Junction-Ambient <sup>1</sup> | ---  | 62   | $^\circ C/W$ |
| $R_{\theta JC}$ | Thermal Resistance Junction-Case <sup>1</sup>    | ---  | 6    | $^\circ C/W$ |



### N-Channel Electrical Characteristics (T<sub>J</sub>=25 °C, unless otherwise noted)

| Symbol                              | Parameter                                      | Conditions   | Min. | Typ.  | Max. | Unit  |
|-------------------------------------|--|--|------|-------|------|-------|
| BV <sub>DSS</sub>                   | Drain-Source Breakdown Voltage                 | V <sub>GS</sub> =0V, I <sub>D</sub> =250uA   | 30   | ---   | ---  | V     |
| ΔBV <sub>DSS</sub> /ΔT <sub>J</sub> | BVDSS Temperature Coefficient                  | Reference to 25°C, I <sub>D</sub> =1mA   | ---  | 0.023 | ---  | V/°C  |
| R <sub>DS(ON)</sub>                 | Static Drain-Source On-Resistance <sup>2</sup> | V <sub>GS</sub> =10V, I <sub>D</sub> =10A  | ---  | 14    | 20   | mΩ    |
|                                     |  | V <sub>GS</sub> =4.5V, I <sub>D</sub> =6A  | ---  | 20    | 25   |       |
| V <sub>GS(th)</sub>                 | Gate Threshold Voltage                         | V <sub>GS</sub> =V <sub>DS</sub> , I <sub>D</sub> =250uA                               | 1.0  | ---   | 2.5  | V     |
| ΔV <sub>GS(th)</sub>                | V <sub>GS(th)</sub> Temperature Coefficient    |  | ---  | -4.2  | ---  | mV/°C |
| I <sub>DSS</sub>                    | Drain-Source Leakage Current                   | V <sub>DS</sub> =24V, V <sub>GS</sub> =0V, T <sub>J</sub> =25°C                        | ---  | ---   | 1    | uA    |
|                                     |  | V <sub>DS</sub> =24V, V <sub>GS</sub> =0V, T <sub>J</sub> =55°C                        | ---  | ---   | 5    |       |
| I <sub>GSS</sub>                    | Gate-Source Leakage Current                    | V <sub>GS</sub> =±20V, V <sub>DS</sub> =0V   | ---  | ---   | ±100 | nA    |
| g <sub>fs</sub>                     | Forward Transconductance                       | V <sub>DS</sub> =5V, I <sub>D</sub> =10A   | ---  | 14    | ---  | S     |
| R <sub>g</sub>                      | Gate Resistance                                | V <sub>DS</sub> =0V, V <sub>GS</sub> =0V, f=1MHz                                       | ---  | 2.3   | ---  | Ω     |
| Q <sub>g</sub>                      | Total Gate Charge (4.5V)                       | V <sub>DS</sub> =20V, V <sub>GS</sub> =4.5V, I <sub>D</sub> =10A                       | ---  | 5     | ---  | nC    |
| Q <sub>gs</sub>                     | Gate-Source Charge                             |  | ---  | 1.11  | ---  |       |
| Q <sub>gd</sub>                     | Gate-Drain Charge                              |  | ---  | 2.61  | ---  |       |
| T <sub>d(on)</sub>                  | Turn-On Delay Time                             | V <sub>DD</sub> =12V, V <sub>GS</sub> =10V, R <sub>G</sub> =3.3Ω<br>I <sub>D</sub> =6A | ---  | 7.7   | ---  | ns    |
| T <sub>r</sub>                      | Rise Time                                      |  | ---  | 46    | ---  |       |
| T <sub>d(off)</sub>                 | Turn-Off Delay Time                            |  | ---  | 11    | ---  |       |
| T <sub>f</sub>                      | Fall Time                                      |  | ---  | 3.6   | ---  |       |
| C <sub>iss</sub>                    | Input Capacitance                              | V <sub>DS</sub> =15V, V <sub>GS</sub> =0V, f=1MHz                                      | ---  | 416   | ---  | pF    |
| C <sub>oss</sub>                    | Output Capacitance                             |  | ---  | 62    | ---  |       |
| C <sub>rss</sub>                    | Reverse Transfer Capacitance                   |  | ---  | 51    | ---  |       |

### Diode Characteristics

| Symbol          | Parameter                                | Conditions  | Min. | Typ. | Max. | Unit |
|-----------------|--|---|------|------|------|------|
| I <sub>S</sub>  | Continuous Source Current <sup>1,5</sup> | V <sub>G</sub> =V <sub>D</sub> =0V, Force Current             | ---  | ---  | 16   | A    |
| I <sub>SM</sub> | Pulsed Source Current <sup>2,5</sup>     |   | ---  | ---  | 30   | A    |
| V <sub>SD</sub> | Diode Forward Voltage <sup>2</sup>       | V <sub>GS</sub> =0V, I <sub>S</sub> =1A, T <sub>J</sub> =25°C | ---  | ---  | 1.2  | V    |

Note :

- 1.The data tested by surface mounted on a 1 inch<sup>2</sup> FR-4 board with 2OZ copper.
- 2.The data tested by pulsed, pulse width ≤ 300us, duty cycle ≤ 2%
- 3.The EAS data shows Max. rating. The test condition is V<sub>DD</sub>=25V, V<sub>GS</sub>=10V, L=0.1mH, I<sub>AS</sub>=12.7A
- 4.The power dissipation is limited by 150°C junction temperature
- 5.The data is theoretically the same as I<sub>D</sub> and I<sub>DM</sub>, in real applications, should be limited by total power dissipation.



### P-Channel Electrical Characteristics ( $T_J=25^\circ\text{C}$ , unless otherwise noted)

| Symbol                       | Parameter                                      | Conditions  | Min. | Typ.   | Max.      | Unit                       |
|------------------------------|--|---|------|--------|-----------|----------------------------|
| $BV_{DSS}$                   | Drain-Source Breakdown Voltage                 | $V_{GS}=0V, I_D=-250\mu A$                          | -30  | ---    | ---       | V                          |
| $\Delta BV_{DSS}/\Delta T_J$ | $BV_{DSS}$ Temperature Coefficient             | Reference to $25^\circ\text{C}$ , $I_D=-1\text{mA}$ | ---  | -0.021 | ---       | $V/^\circ\text{C}$         |
| $R_{DS(ON)}$                 | Static Drain-Source On-Resistance <sup>2</sup> | $V_{GS}=-10V, I_D=-8A$                              | ---  | 25     | 30        | m $\Omega$                 |
|                              |  | $V_{GS}=-4.5V, I_D=-6A$                             | ---  | 30     | 35        |                            |
| $V_{GS(th)}$                 | Gate Threshold Voltage                         | $V_{GS}=V_{DS}, I_D=-250\mu A$                      | -1.0 | ---    | -2.5      | V                          |
| $\Delta V_{GS(th)}$          | $V_{GS(th)}$ Temperature Coefficient           |   | ---  | -4.2   | ---       | $\text{mV}/^\circ\text{C}$ |
| $I_{DSS}$                    | Drain-Source Leakage Current                   | $V_{DS}=-24V, V_{GS}=0V, T_J=25^\circ\text{C}$      | ---  | ---    | 1         | $\mu A$                    |
|                              |  | $V_{DS}=-24V, V_{GS}=0V, T_J=55^\circ\text{C}$      | ---  | ---    | 5         |                            |
| $I_{GSS}$                    | Gate-Source Leakage Current                    | $V_{GS}=\pm 20V, V_{DS}=0V$                         | ---  | ---    | $\pm 100$ | nA                         |
| gfs                          | Forward Transconductance                       | $V_{DS}=-5V, I_D=-8A$                               | ---  | 12.6   | ---       | S                          |
| $R_g$                        | Gate Resistance                                | $V_{DS}=0V, V_{GS}=0V, f=1\text{MHz}$               | ---  | 15     | ---       | $\Omega$                   |
| $Q_g$                        | Total Gate Charge (-4.5V)                      | $V_{DS}=-20V, V_{GS}=-4.5V, I_D=-6A$                | ---  | 9.8    | ---       | nC                         |
| $Q_{gs}$                     | Gate-Source Charge                             |   | ---  | 2.2    | ---       |                            |
| $Q_{gd}$                     | Gate-Drain Charge                              |   | ---  | 3.4    | ---       |                            |
| $T_{d(on)}$                  | Turn-On Delay Time                             | $V_{DD}=-24V, V_{GS}=-10V, R_G=3.3\Omega, I_D=-1A$  | ---  | 16.4   | ---       | ns                         |
| $T_r$                        | Rise Time                                      |   | ---  | 20.2   | ---       |                            |
| $T_{d(off)}$                 | Turn-Off Delay Time                            |   | ---  | 55     | ---       |                            |
| $T_f$                        | Fall Time                                      |   | ---  | 10     | ---       |                            |
| $C_{iss}$                    | Input Capacitance                              | $V_{DS}=-15V, V_{GS}=0V, f=1\text{MHz}$             | ---  | 930    | ---       | pF                         |
| $C_{oss}$                    | Output Capacitance                             |   | ---  | 148    | ---       |                            |
| $C_{rss}$                    | Reverse Transfer Capacitance                   |   | ---  | 115    | ---       |                            |

### Diode Characteristics

| Symbol   | Parameter                                | Conditions                                 | Min. | Typ. | Max. | Unit |
|----------|--|--|------|------|------|------|
| $I_S$    | Continuous Source Current <sup>1,5</sup> | $V_G=V_D=0V$ , Force Current               | ---  | ---  | -14  | A    |
| $I_{SM}$ | Pulsed Source Current <sup>2,5</sup>     |  | ---  | ---  | -24  | A    |
| $V_{SD}$ | Diode Forward Voltage <sup>2</sup>       | $V_{GS}=0V, I_S=-1A, T_J=25^\circ\text{C}$ | ---  | ---  | -1.2 | V    |

Note :

1. The data tested by surface mounted on a 1 inch<sup>2</sup> FR-4 board with 2OZ copper.
2. The data tested by pulsed, pulse width  $\leq 300\mu s$ , duty cycle  $\leq 2\%$
3. The EAS data shows Max. rating. The test condition is  $V_{DD}=-25V, V_{GS}=-10V, L=0.1\text{mH}, I_{AS}=-30A$
4. The power dissipation is limited by  $150^\circ\text{C}$  junction temperature
5. The data is theoretically the same as  $I_D$  and  $I_{DM}$ , in real applications, should be limited by total power dissipation.



### N-Channel Typical Characteristics

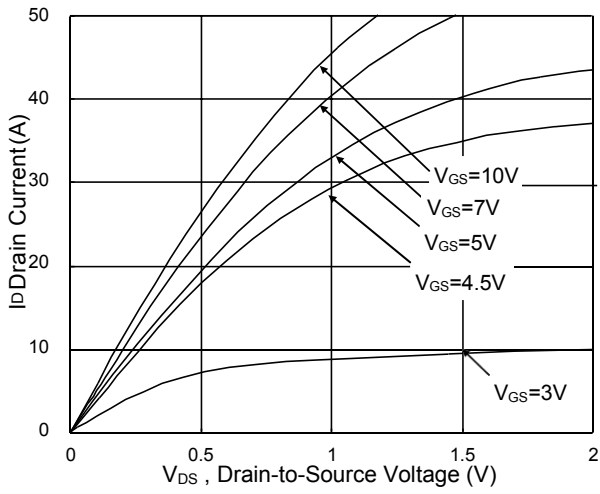

Fig.1 Typical Output Characteristics

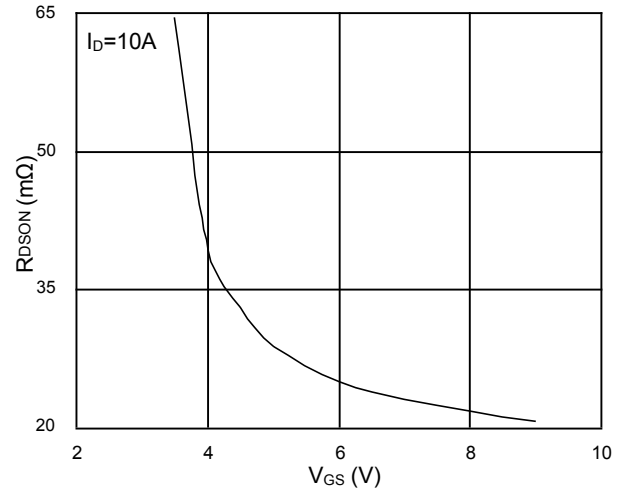

Fig.2 On-Resistance vs. Gate-Source

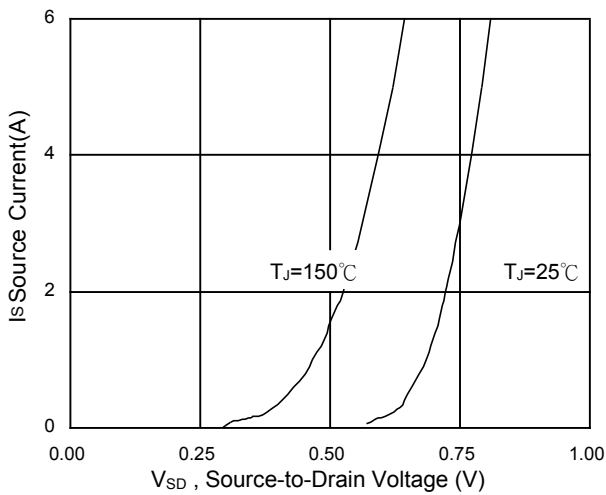

Fig.3 Forward Characteristics Of Reverse

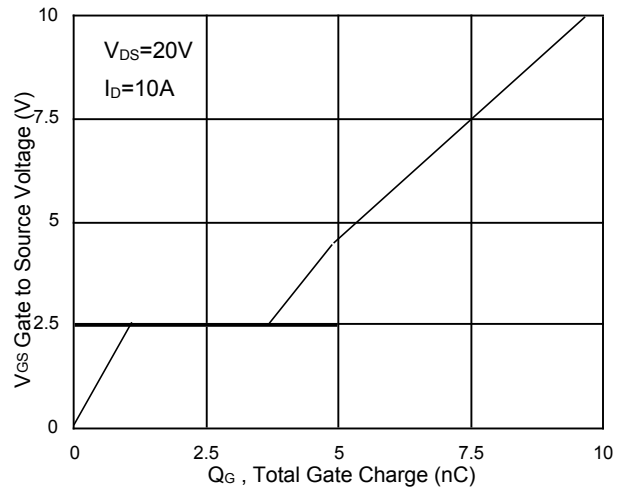

Fig.4 Gate-Charge Characteristics

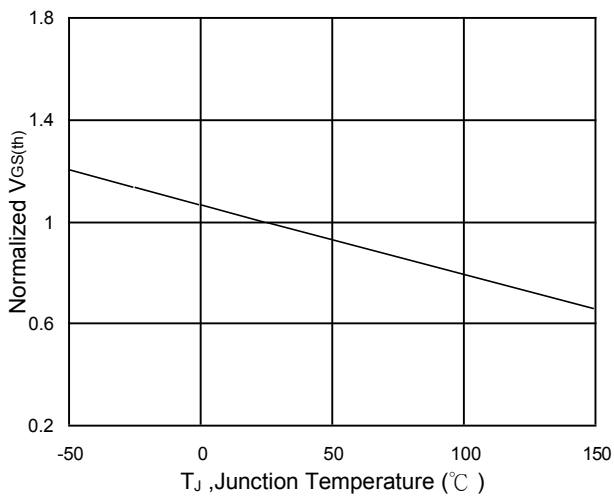

Fig.5 Normalized  $V_{GS(th)}$  vs.  $T_J$

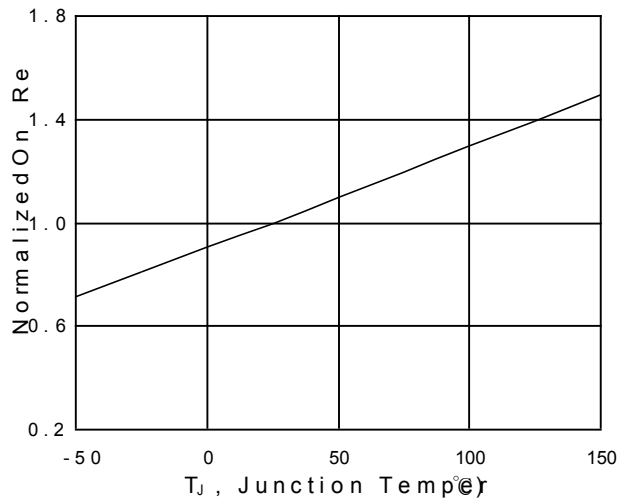
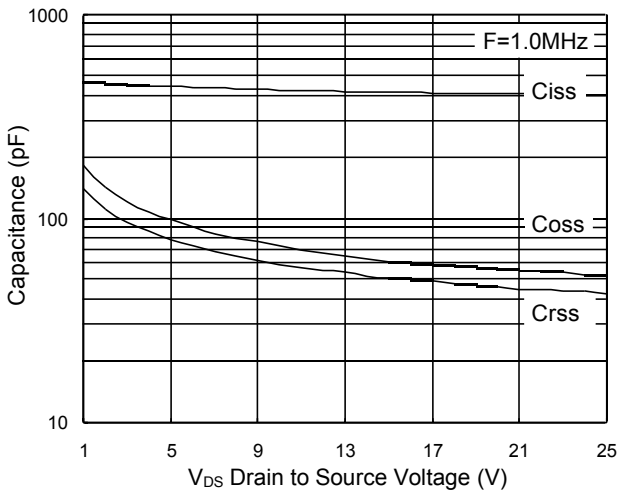
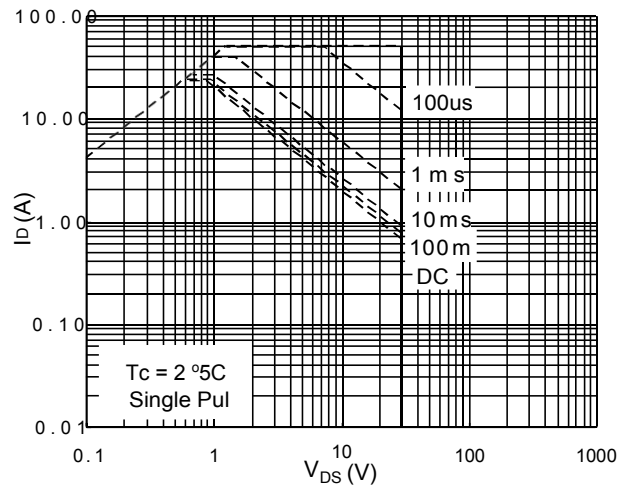

Fig.6 Normalized  $R_{DS(on)}$  vs.  $T_J$



**Fig.7 Capacitance**



**Fig.8 Safe Operating Area**

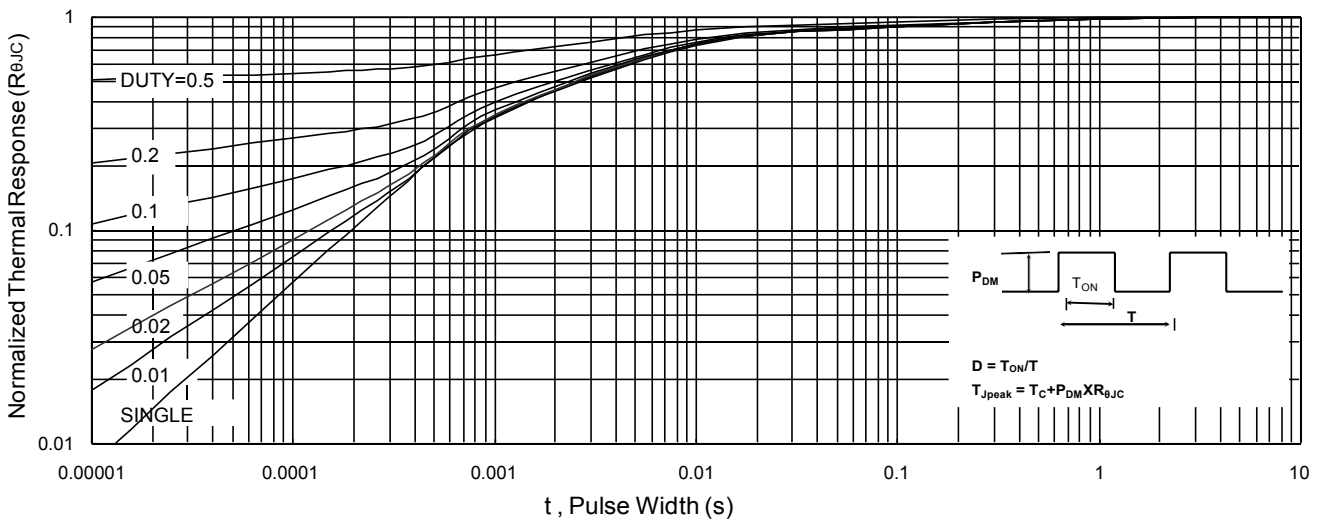

**Fig.9 Normalized Maximum Transient Thermal Impedance**

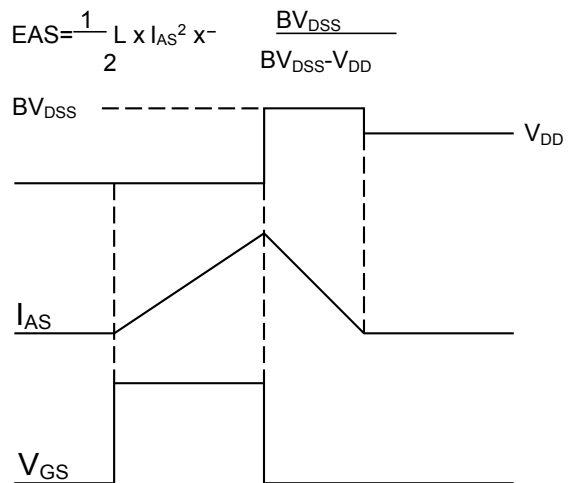
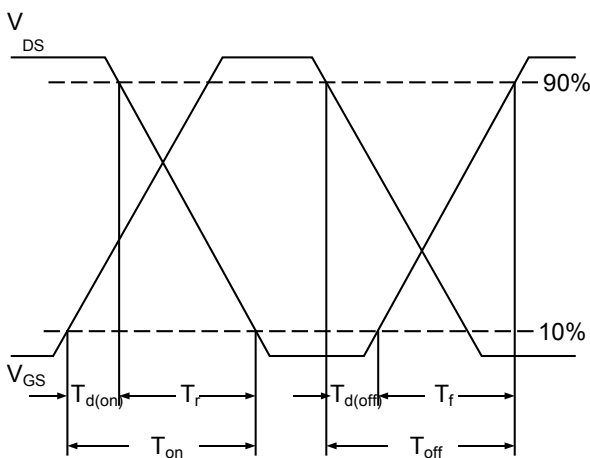



### P-Channel Typical Characteristics

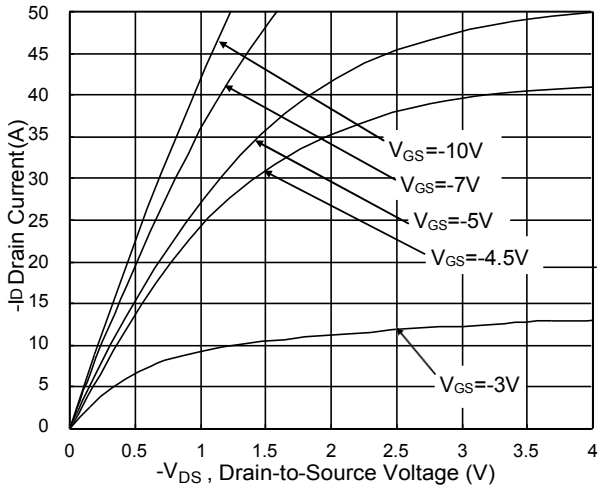

Fig.1 Typical Output Characteristics

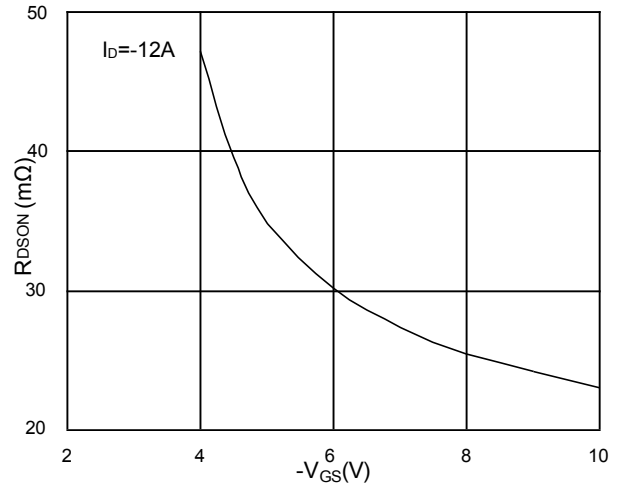

Fig.2 On-Resistance v.s Gate-Source

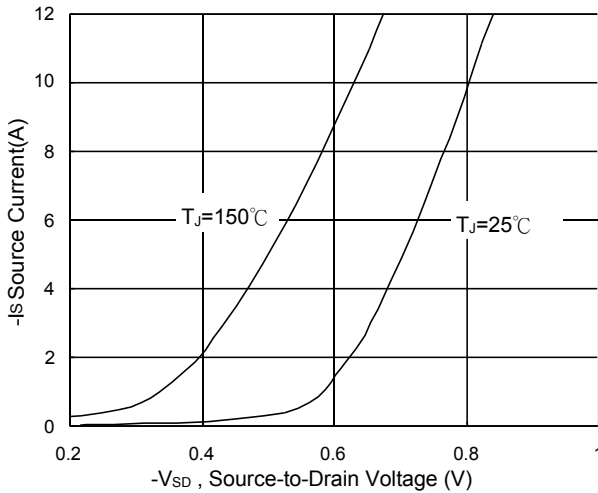

Fig.3 Forward Characteristics Of Reverse

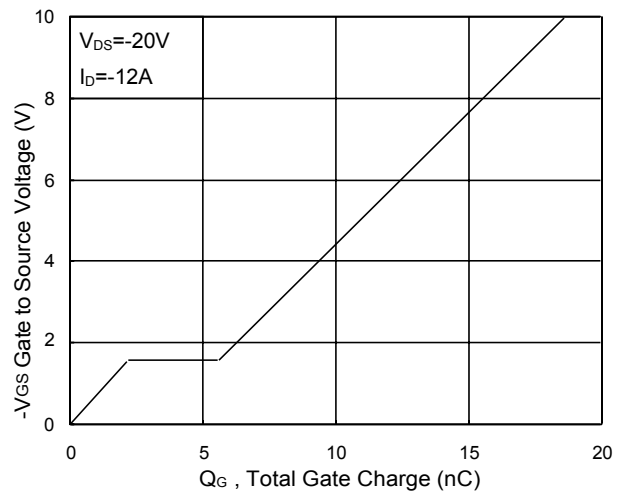

Fig.4 Gate-Charge Characteristics

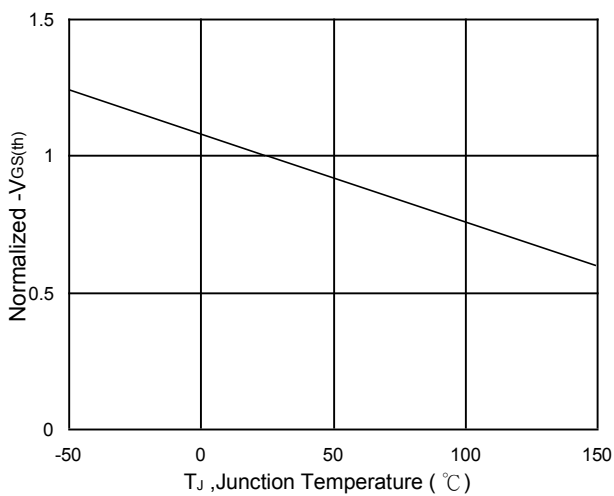

Fig.5 Normalized  $V_{GS(th)}$  v.s  $T_J$

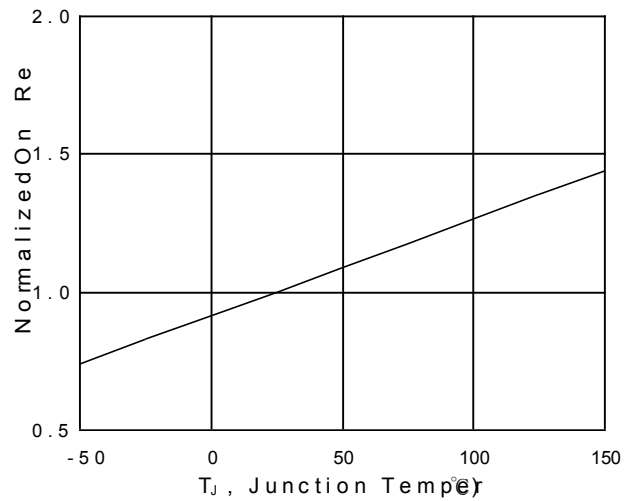
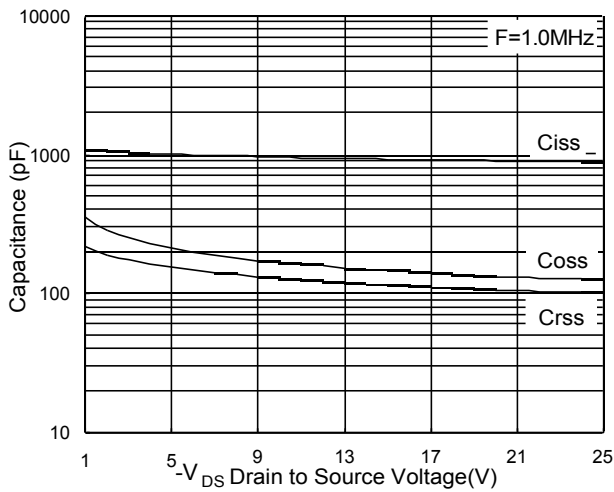
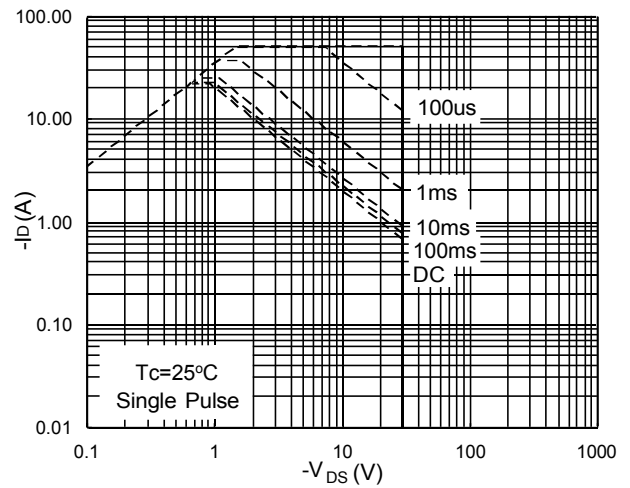

Fig.6 Normalized  $R_{DS(on)}$  v.s  $T_J$



**Fig.7 Capacitance**



**Fig.8 Safe Operating Area**

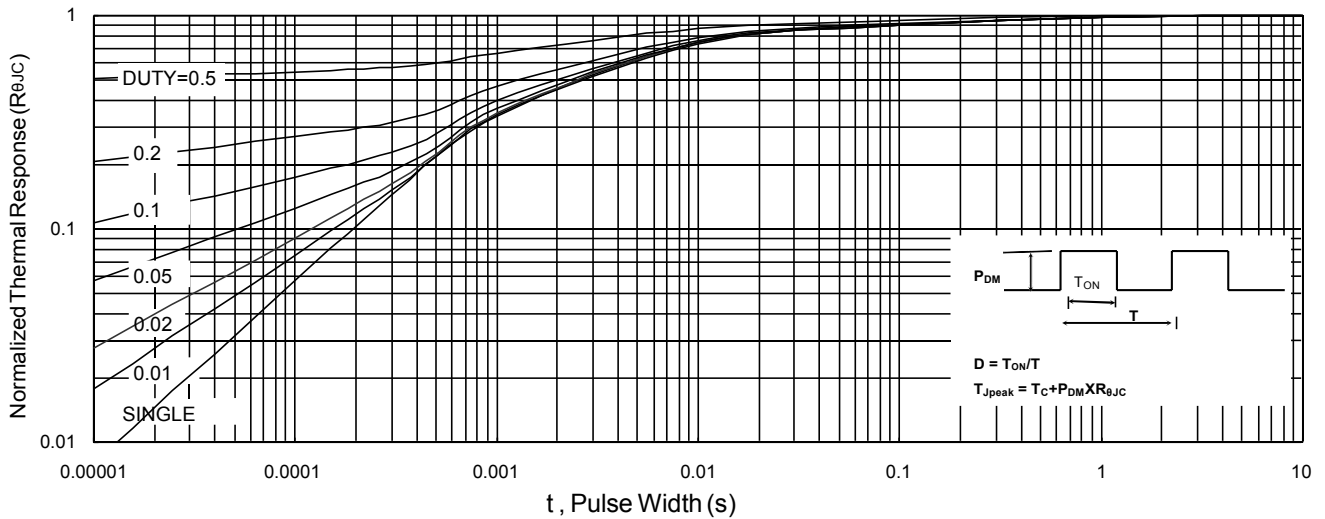

**Fig.9 Normalized Maximum Transient Thermal Impedance**

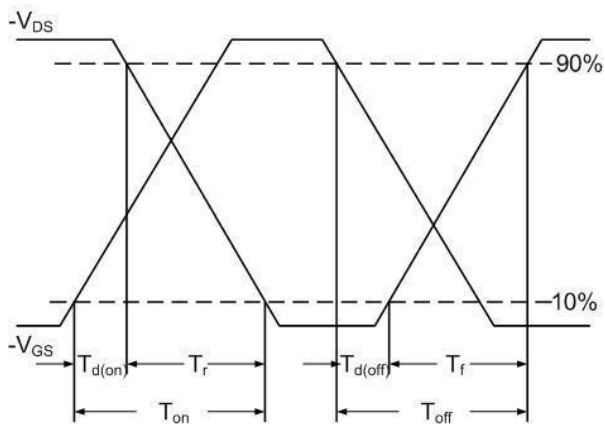

**Fig.10 Switching Time Waveform**

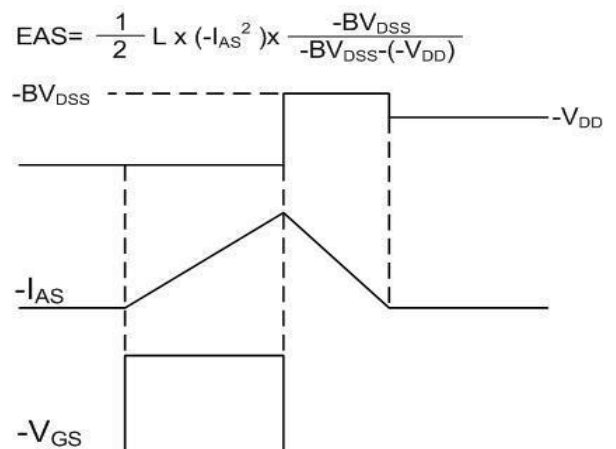

**Fig.11 Unclamped Inductive Switching Waveform**



### Dual PDFN3333-8L Package Outline Data

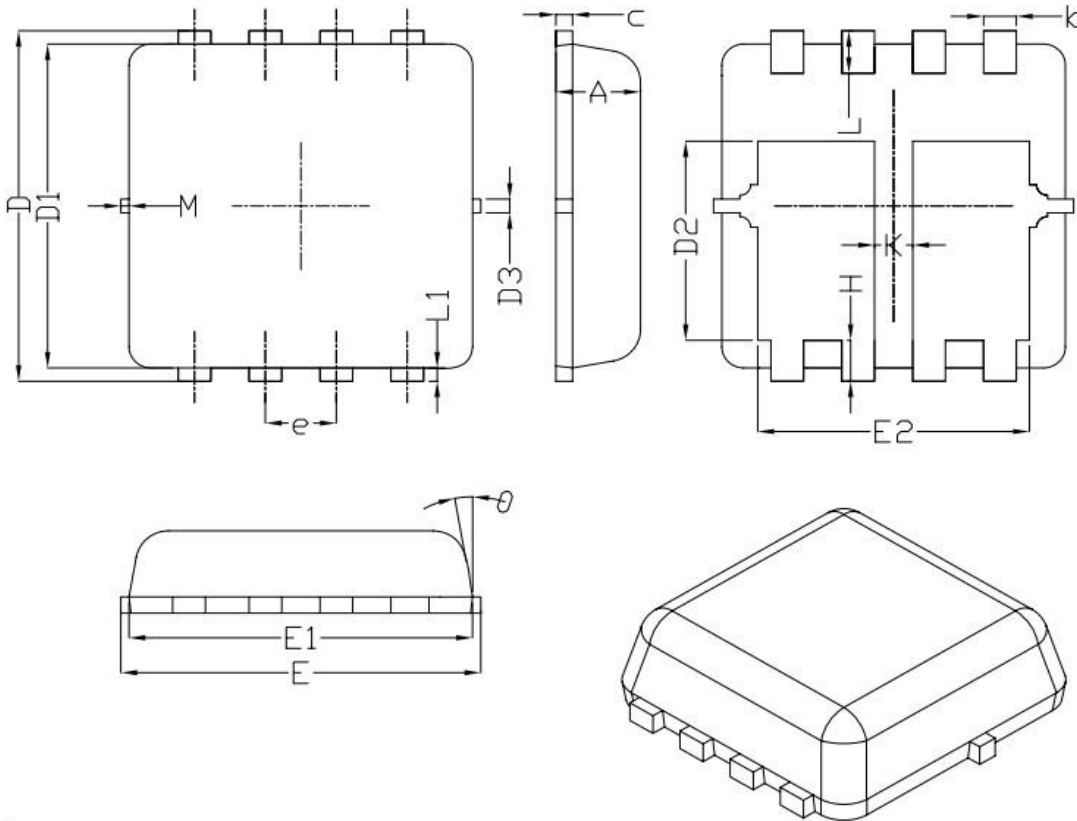

| Symbol          | Dimensions (unit: mm) |      |      |
|-----------------|-----------------------|------|------|
|                 | Min                   | Typ  | Max  |
| A               | 0.70                  | 0.75 | 0.80 |
| b               | 0.25                  | 0.30 | 0.35 |
| c               | 0.10                  | 0.15 | 0.25 |
| D               | 3.25                  | 3.35 | 3.45 |
| D1              | 3.00                  | 3.10 | 3.20 |
| D2              | 1.78                  | 1.88 | 1.98 |
| D3              | --                    | 0.13 | --   |
| E               | 3.20                  | 3.30 | 3.40 |
| E1              | 3.00                  | 3.15 | 3.20 |
| E2              | 2.39                  | 2.49 | 2.59 |
| e               | 0.65 BSC              |      |      |
| H               | 0.30                  | 0.39 | 0.50 |
| L               | 0.30                  | 0.40 | 0.50 |
| L1              | --                    | 0.13 | --   |
| K               | 0.30                  | --   | --   |
| θ               | --                    | 10°  | 12°  |
| M               | *                     | *    | 0.15 |
| * Not Specified |                       |      |      |

Notes:

1. Refer to JEDEC MO-240 variation CA.
2. Dimensions "D1" and "E1" do NOT include mold flash protrusions or gate burrs.
3. Dimensions "D1" and "E1" include interterminal flash or protrusion.



## Disclaimer

Brunei has made reasonable commercial efforts to ensure that the information given in this datasheet is correct. However, it must clearly be understood that such information is for guidance only and does not constitute any representation or form part of any offer or contract.

For documents and material available from this datasheet, Brunei does not warrant or assume any legal liability or responsibility for the accuracy, completeness, or usefulness of any information, product, technology or process disclosed hereunder.

Brunei reserves the rights to at its own discretion to make any changes or improvements to this datasheet. Unless said datasheet is incorporated into the formal contract, any customer should not rely on the information as any specification or product parameters duly committed by Brunei Customers are hereby advised to verify that the information contained herein is current and complete before the entering of any contract or acknowledgement of any purchase order. Accordingly, all products specified hereunder shall be sold subject to Brunei's terms and conditions supplied at the time of order acknowledgement. Except where agreed upon by contractual agreement, testing of all parameters of each product is not necessarily performed.

Brunei does not warrant or convey any license either expressed or implied under its patent rights, nor the rights of others. Reproduction of information contained herein shall be only permissible if such reproduction is without any modification or alteration. Reproduction of this information with any alteration is an unfair and deceptive business practice. Brunei is not responsible or liable for such altered documentation.

Resale of Brunei's products with statements different from or beyond the parameters stated by Brunei for that product or service voids all express or implied warranties for the associated Brunei's product or service and is unfair and deceptive business practice. Brunei is not responsible or liable for any such statements.

Brunei's products are not authorized for use as critical components in life support devices or systems without the express written approval of Brunei. As used herein:

1. Life support devices or systems are devices or systems which, (a) are intended for surgical implant into the body, or (b) support or sustain life, and whose failure to perform, when properly used in accordance with instructions for use provided in the labeling, can be reasonably expected to result in a significant injury to the user.
2. A critical component is any component of a life support device or system whose failure to perform can be reasonably expected to cause the failure of the life support device or system, or to affect its safety or effectiveness.