

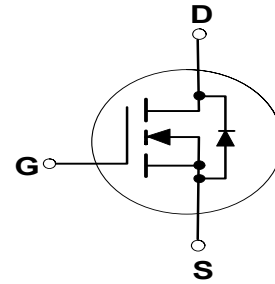

85V N-Channel PowerTrench MOSFET

Features

- Uses advanced SGT technology
- Extremely low on-resistance $R_{DS(on)}$
- Excellent gate charge x $R_{DS(on)}$ product(FOM)



Application

- Motor control and drives
- Battery management
- DC/DC converter
- General purpose applications

- Typical $R_{DS(on)} = 1.30\text{ m}\Omega$ at $V_{GS} = 10\text{V}$, $I_D = 50\text{ A}$
- UIS Capability
- RoHS Compliant

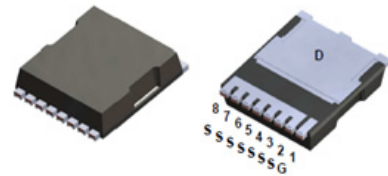

Maximum Ratings

Parameter	Symbol	Value	Unit
Drain-source voltage	V_{DS}	80	V
Continuous drain current $T_C = 25^\circ\text{C}$ (Silicon limit) $T_C = 100^\circ\text{C}$ (Silicon limit)	I_D	255 234	A
Pulsed drain current $T_C = 25^\circ\text{C}$, t_p limited by T_{jmax}	$I_{D\text{ pulse}}$	950	
Avalanche energy, single pulse (L=0.5mH,Rg=25 Ω)	E_{AS}	2704	mJ
Gate-Source voltage	V_{GS}	± 20	V
Power dissipation $T_C = 25^\circ\text{C}$	P_D	312	W
Operating junction and storage temperature	T_j, T_{stg}	-55~150	$^\circ\text{C}$

Thermal Resistance

	Symbol	Value	Unit
Thermal resistance, junction – case. Max	R_{thJC}	0.4	$^\circ\text{C}/\text{W}$
Thermal resistance, junction – ambient. Max	R_{thJA}	42	



85V N-Channel PowerTrench MOSFET

Electrical Characteristic, at $T_j = 25\text{ }^\circ\text{C}$, unless otherwise specified

Parameter	Symbol	Test Condition	Value			Unit
			min.	typ.	max.	

Static Characteristic

Drain-source breakdown voltage	$V_{(BR)DSS}$	$V_{GS}=0V, I_D=250\mu A$	80	-	-	V
Gate threshold voltage	$V_{GS(th)}$	$V_{DS}=V_{GS}, I_D=250\mu A$ $T_j=25^\circ C$	2	3	4	
Zero gate voltage drain current	I_{DSS}	$V_{DS}=80V, V_{GS}=0V$ $T_j=25^\circ C$	-	-	1	μA
		$V_{DS}=64V, T_j=125^\circ C$	-	-	10	
Gate-source leakage current	I_{GSS}	$V_{GS}=20V, V_{DS}=0V$	-	-	100	nA
Drain-source on-state resistance	$R_{DS(on)}$	$V_{GS}=10V, I_D=50A,$ $T_j=25^\circ C$	-	1.30	1.6	$m\Omega$
Transconductance	g_{fs}	$V_{DS}=5V, I_D=40A$	-	227	-	S

Dynamic Characteristic

Input Capacitance	C_{iss}	$V_{GS}=0V, V_{DS}=40V,$ $f=1MHz$	-	13611	-	pF
Output Capacitance	C_{oss}		-	2340	-	
Reverse Transfer Capacitance	C_{rss}		-	939	-	
Gate Total Charge	Q_G	$V_{GS}=10V, V_{DS}=40V,$ $I_D=50A$	-	205	-	nC
Gate-Source charge	Q_{gs}		-	54	-	
Gate-Drain charge	Q_{gd}		-	46	-	
Turn-on delay time	$t_{d(on)}$	$T_j=25^\circ C, V_{GS}=10V,$ $V_{DS}=40V, R_L=3\Omega$	-	38	-	ns
Rise time	t_r		-	132	-	
Turn-off delay time	$t_{d(off)}$		-	126	-	
Fall time	t_f		-	153	-	
Gate resistance	R_G	$V_{GS}=0V, V_{DS}=0V,$ $f=1MHz$	-	1.85	-	Ω

Body Diode Characteristic

Body Diode Forward Voltage	V_{SD}	$V_{GS}=0V, I_{SD}=50A$	-	0.8	1.2	V
Body Diode Reverse Recovery Time	t_{rr}	$I_F=30A,$ $dI/dt=500A/\mu s$	-	112	-	ns
Body Diode Reverse Recovery Charge	Q_{rr}	$I_F=30A,$ $dI/dt=500A/\mu s$	-	220	-	nC



Typical Performance Characteristics

Fig 1: Output Characteristics

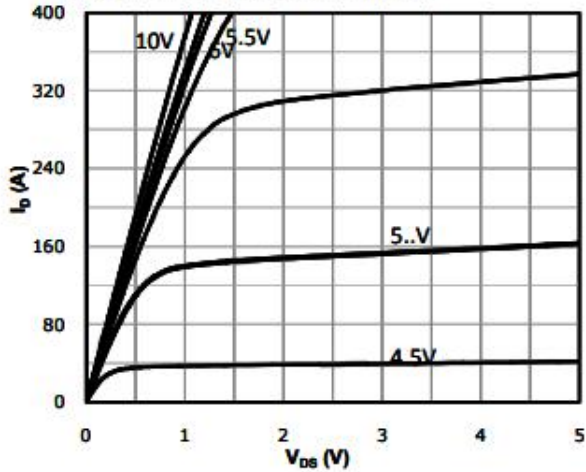

Fig 2: Transfer Characteristics

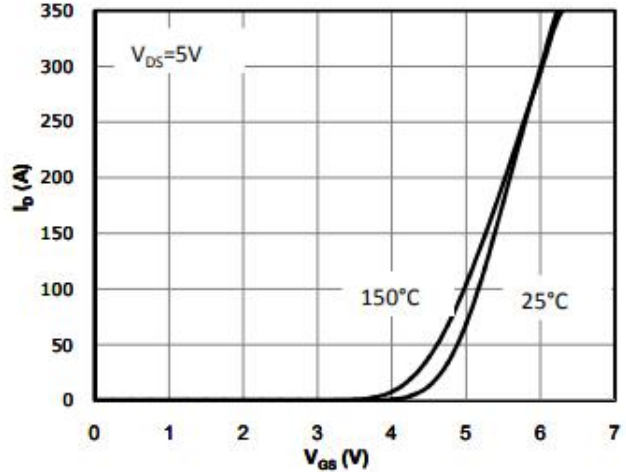

Figure 3. Rds(on) vs Drain Current and

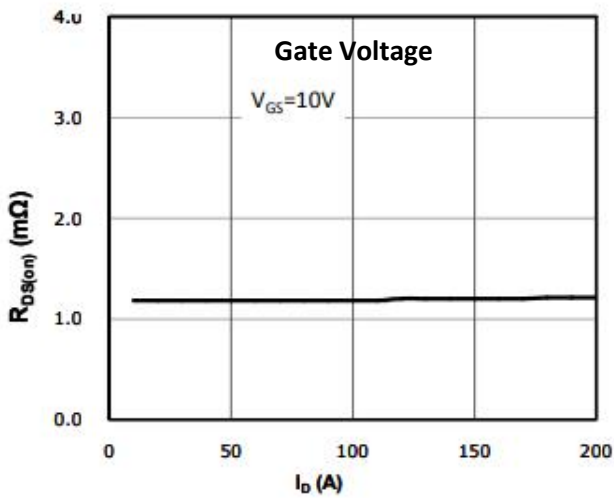

Fig 4: Rds(on) vs Gate Voltage

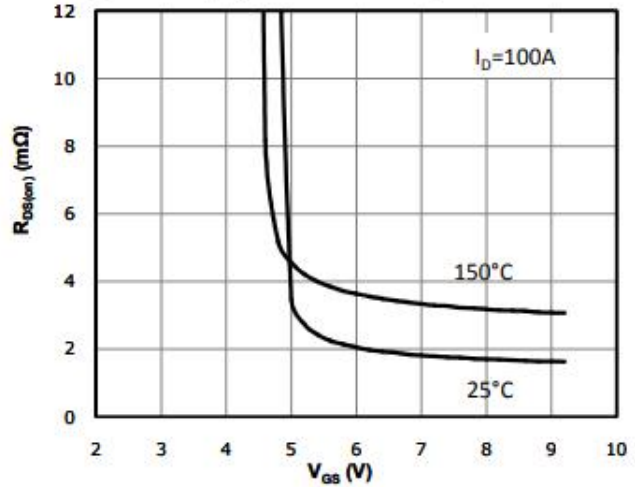

Fig 5: Rds(on) vs. Temperature

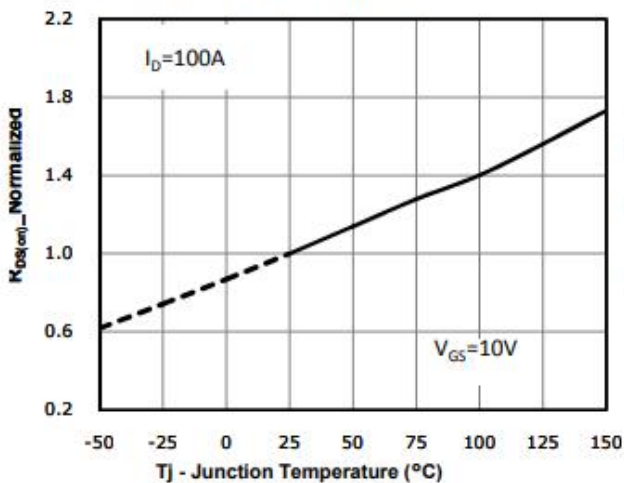
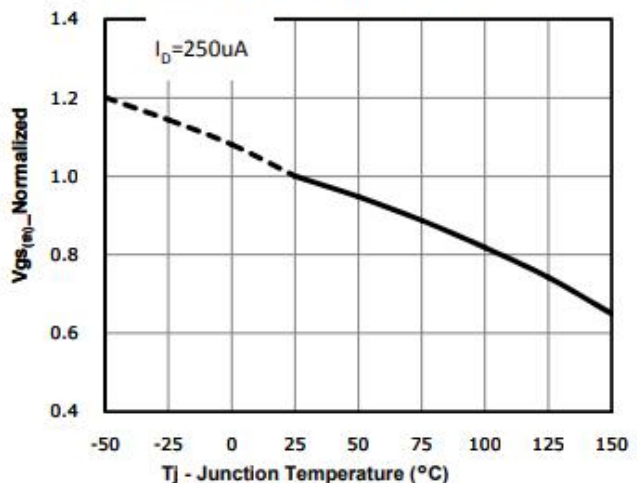

Fig 6: Vgs(th) vs. Temperature





85V N-Channel PowerTrench MOSFET

Fig 7: BV_{DS} vs. Temperature

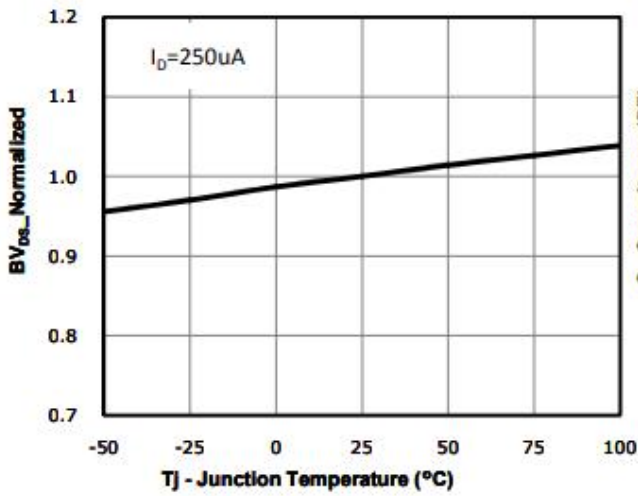

Fig 8: Capacitance Characteristics

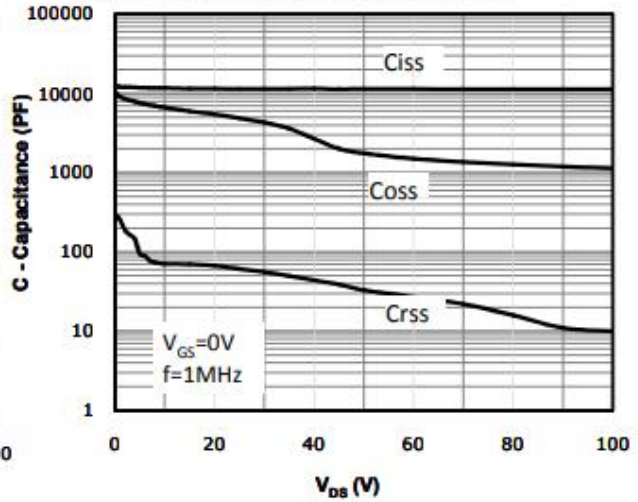

Fig 9: Gate Charge Characteristics

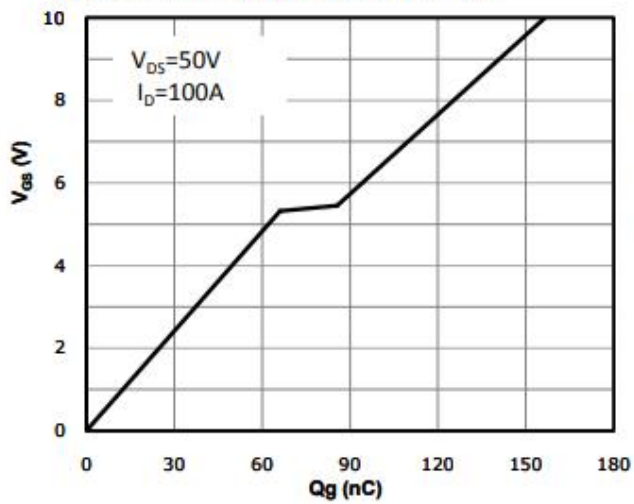

Fig 10: Body-diode Forward Characteristics

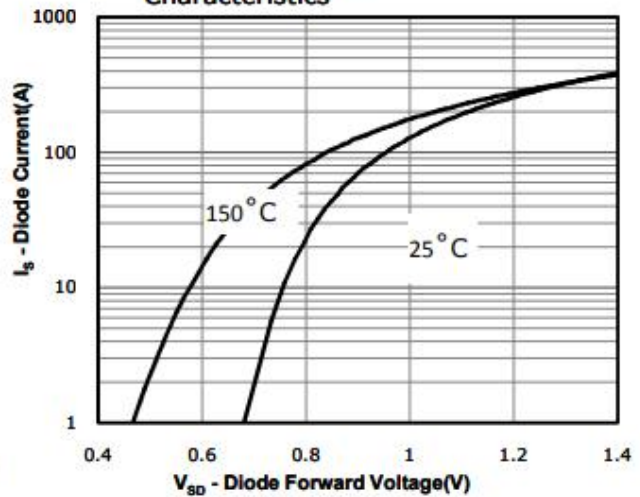

Fig 11: Power Dissipation

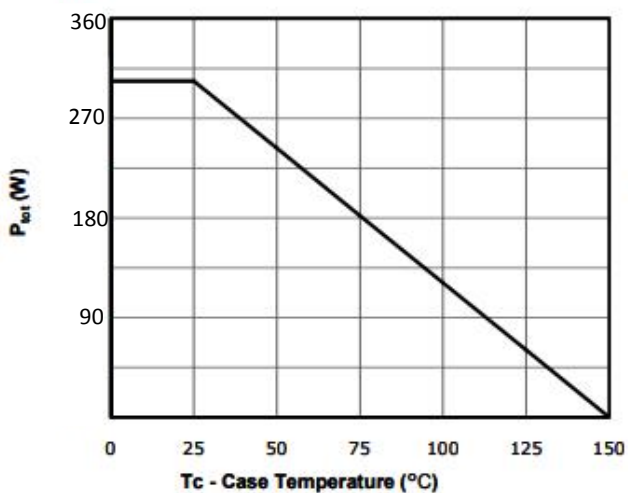

Fig 12: Drain Current Derating

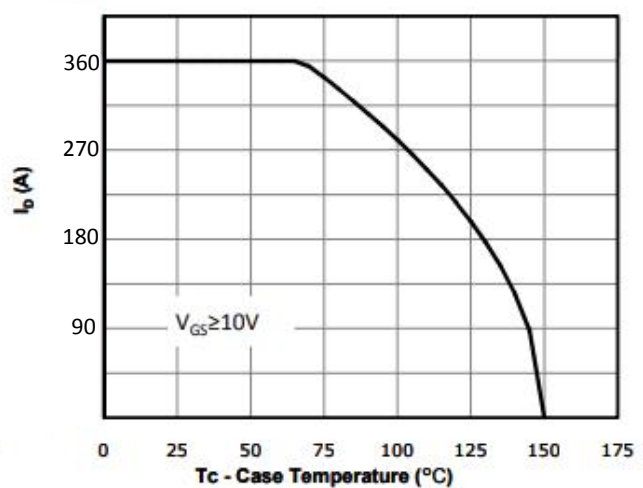



Fig 13: Safe Operating Area

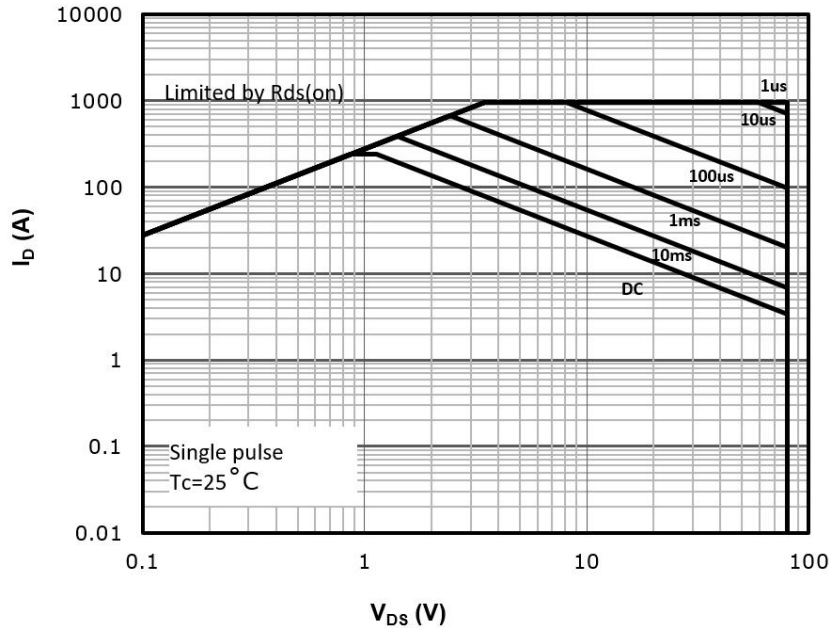
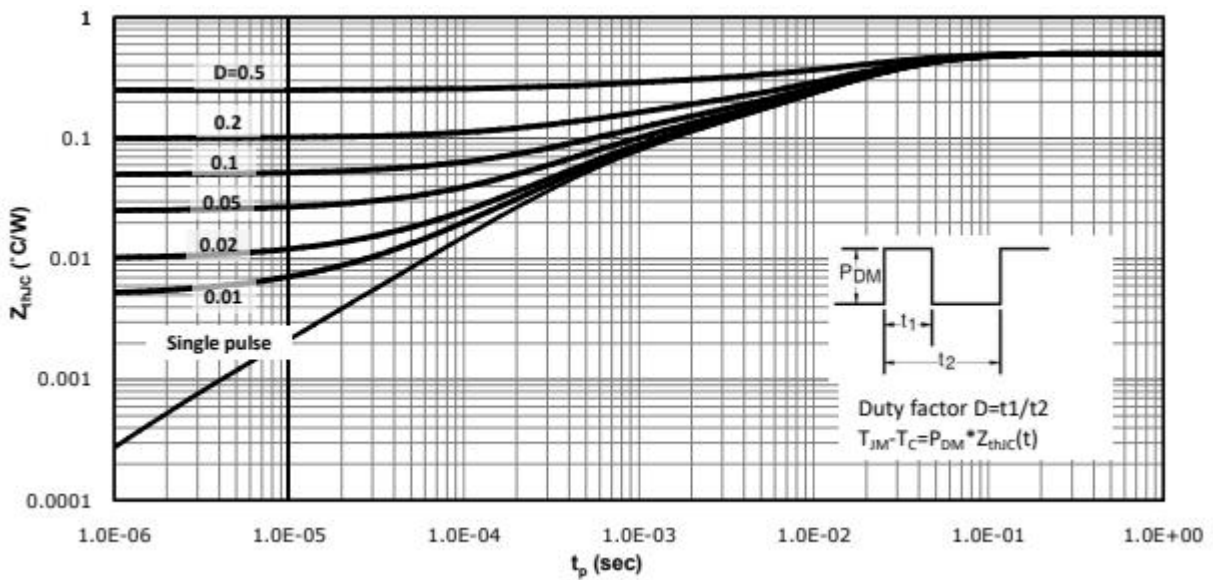

Fig 14: Max. Transient Thermal impedance





Test Circuit & Waveform

Gate Charge Test Circuit & Waveform

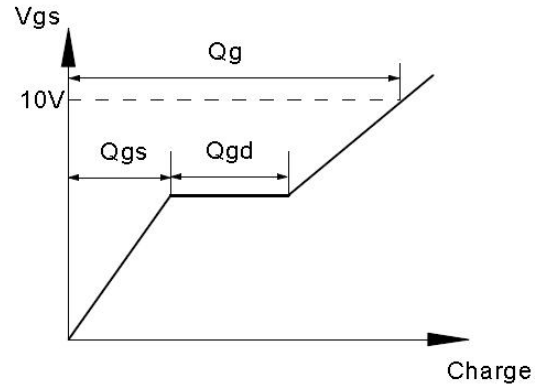
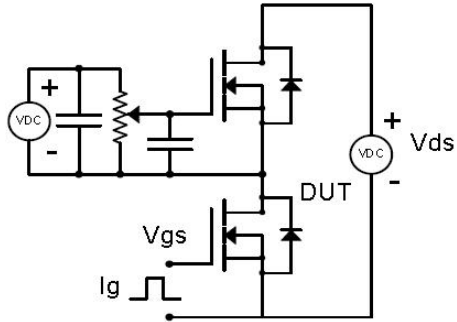

Resistive Switching Test Circuit & Waveforms

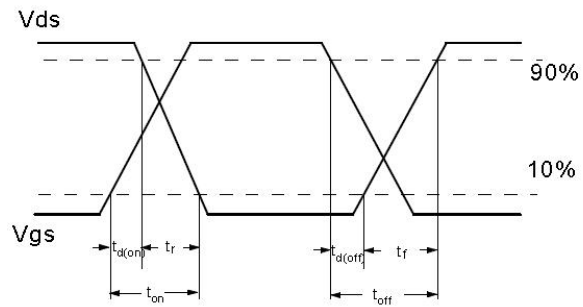
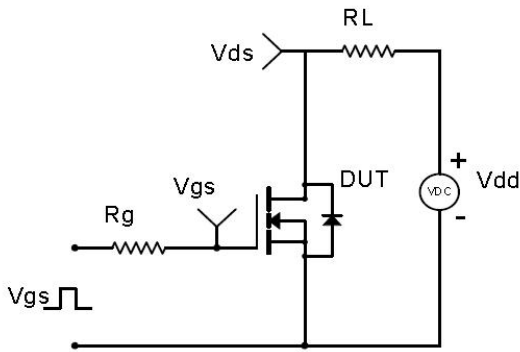

Unclamped Inductive Switching (UIS) Test Circuit & Waveforms

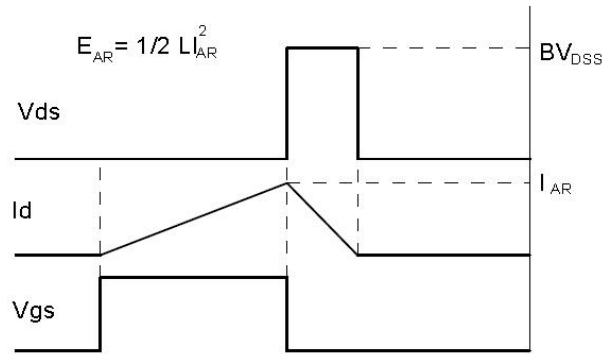
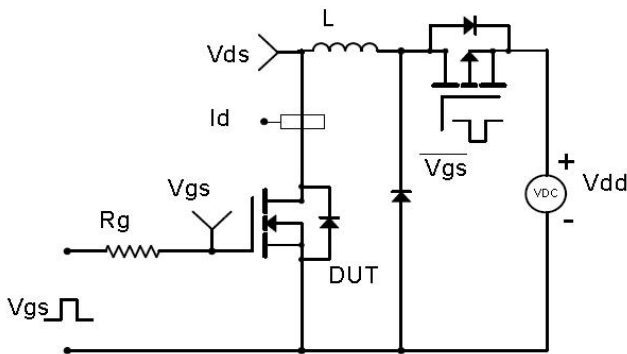

Diode Recovery Test Circuit & Waveforms

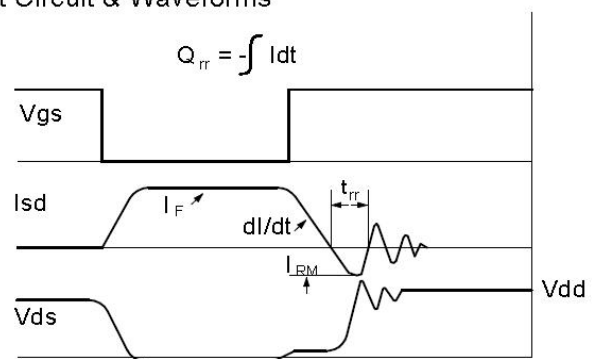
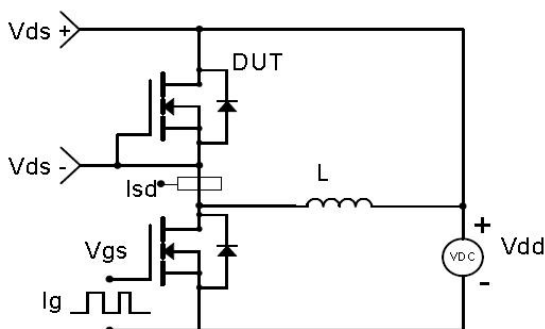



Package Outline: TOLL

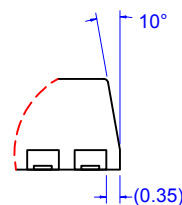
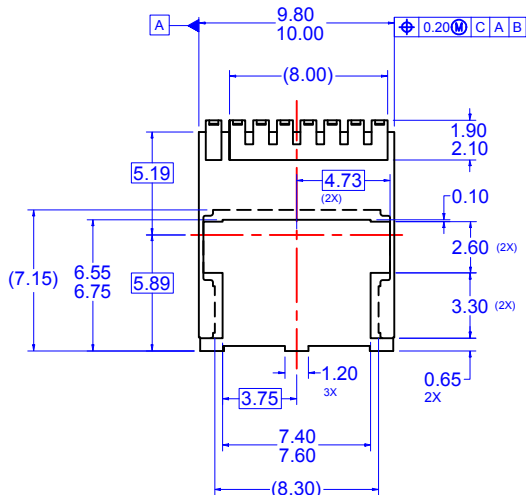
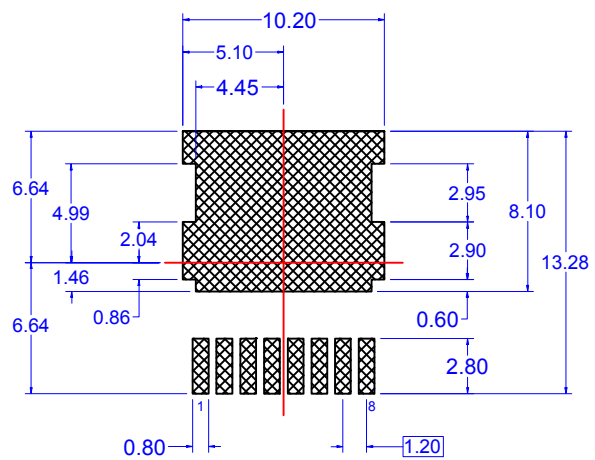
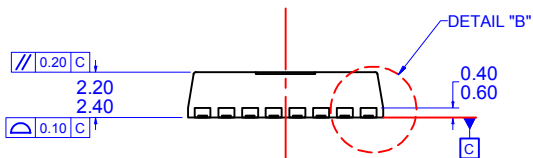
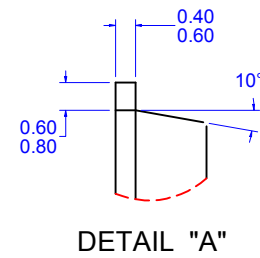
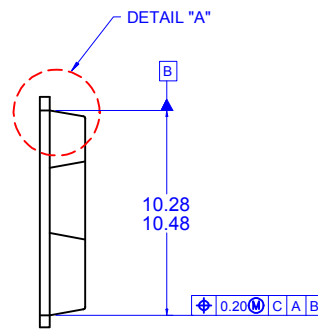
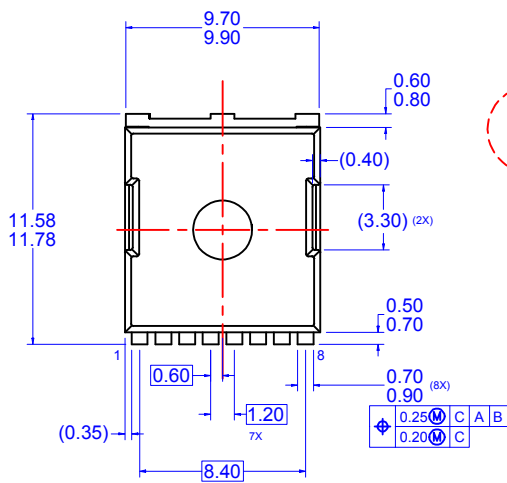

DETAIL "B"