

**40V N-Channel MOSFET****FEATURES**

- ★ Fast switching
- ★ 100% avalanche tested
- ★ Improved dv/dt capability

**APPLICATIONS**

- ★ Switch Mode Power Supply (SMPS)
- ★ Uninterruptible Power Supply (UPS)
- ★ Hard switched and high frequency circuits

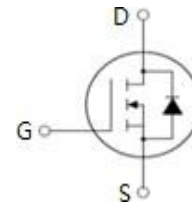

Absolute Maximum Ratings $T_C = 25^\circ\text{C}$, unless otherwise noted			
Parameter	Symbol	Value	Unit
		TO-220	
Drain-Source Voltage ($V_{GS} = 0V$)	V_{DSS}	40	V
Continuous Drain Current $V_{GS} = 10V$ $T_C = 25^\circ\text{C}$	I_D	162 (note5)	A
Pulsed Drain Current (note1)	I_{DM}	648	A
Gate-Source Voltage	V_{GSS}	± 20	V
Single Pulse Avalanche Energy (note2)	E_{AS}	1980	mJ
Avalanche Current (note1)	I_{AS}	95	A
Repetitive Avalanche Energy (note1)	E_{AR}	1188	mJ
Power Dissipation ($T_C = 25^\circ\text{C}$)	P_D	171	W
Peak Diode Recovery dv/dt (note1)	dv/dt	5.0	
Operating Junction and Storage Temperature Range	T_J, T_{stg}	-55~+150	$^\circ\text{C}$

Thermal Resistance			
Parameter	Symbol	Value	Unit
Thermal Resistance, Junction-to-Case	R_{thJC}	0.73	$^\circ\text{C/W}$
Thermal Resistance, Junction-to-Ambient	R_{thJA}	62.5	



Specifications $T_J = 25^\circ\text{C}$, unless otherwise noted						
Parameter	Symbol	Test Conditions	Value			Unit
			Min.	Typ.	Max.	
Static						
Drain-Source Breakdown Voltage	$V_{(BR)DSS}$	$V_{GS} = 0V, I_D = 250\mu A$	40	--	--	V
Zero Gate Voltage Drain Current	I_{DSS}	$V_{DS} = 40V, V_{GS} = 0V, T_J = 25^\circ\text{C}$	--	--	20	μA
		$V_{DS} = 32V, V_{GS} = 0V, T_J = 125^\circ\text{C}$	--	--	250	
Gate-Source Leakage	I_{GSS}	$V_{GS} = \pm 20V$	--	--	± 200	nA
Gate-Source Threshold Voltage	$V_{GS(th)}$	$V_{DS} = V_{GS}, I_D = 250\mu A$	2.0	--	4.0	V
Drain-Source On-Resistance (Note3)	$R_{DS(on)}$	$V_{GS} = 10V, I_D = 60A(\text{Note4})$	--	4	5	m Ω
Dynamic						
Input Capacitance	C_{iss}	$V_{GS} = 0V, V_{DS} = 25V, f = 1.0\text{MHz}$	--	3840	--	pF
Output Capacitance	C_{oss}		--	1710	--	
Reverse Transfer Capacitance	C_{rss}		--	470	--	
Total Gate Charge	Q_g	$V_{DD} = 20V, I_D = 162A, V_{GS} = 10V (\text{Note4})$	--	96	--	nC
Gate-Source Charge	Q_{gs}		--	19	--	
Gate-Drain Charge	Q_{gd}		--	46	--	
Turn-on Delay Time	$t_{d(on)}$	$V_{DD} = 20V, I_D = 162A, R_G = 10\Omega, V_{GS} = 10V (\text{Note4})$	--	32	--	ns
Turn-on Rise Time	t_r		--	92	--	
Turn-off Delay Time	$t_{d(off)}$		--	101	--	
Turn-off Fall Time	t_f		--	69	--	
Drain-Source Body Diode Characteristics						
Continuous Body Diode Current	I_S	$T_C = 25^\circ\text{C}$	--	--	162	A
Pulsed Diode Forward Current	I_{SM}		--	--	650	
Body Diode Voltage	V_{SD}	$T_J = 25^\circ\text{C}, I_{SD} = 60A, V_{GS} = 0V$	--	--	1.3	V
Reverse Recovery Time	t_{rr}	$V_{GS} = 0V, I_S = 162A, di_F/dt = 100A/\mu s$	--	78	--	ns
Reverse Recovery Charge	Q_{rr}		--	200	--	μC

Notes

1. Repetitive Rating: Pulse width limited by maximum junction temperature
2. Starting $T_J = 25^\circ\text{C}, L=1\text{mH}, V_{DD} = 20V$
3. $I_{SD} \leq 95A, di/dt \leq 150A/\mu s, V_{DD} \leq V_{(BR)DSS}, T_J = 175^\circ\text{C}$
4. Pulse Test: Pulse width $\leq 300\mu s$, Duty Cycle $\leq 2\%$
5. Calculated continuous current based on maximum allowable junction temperature, Package limitation current is 75A



40V N-Channel MOSFET

Typical Characteristics $T_J = 25^\circ\text{C}$, unless otherwise noted

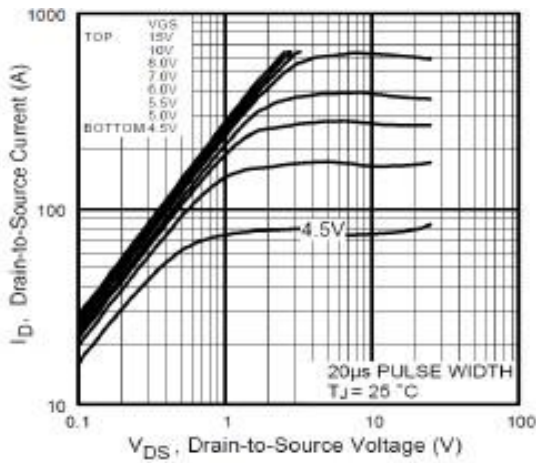

Fig 1. Typical Output Characteristics

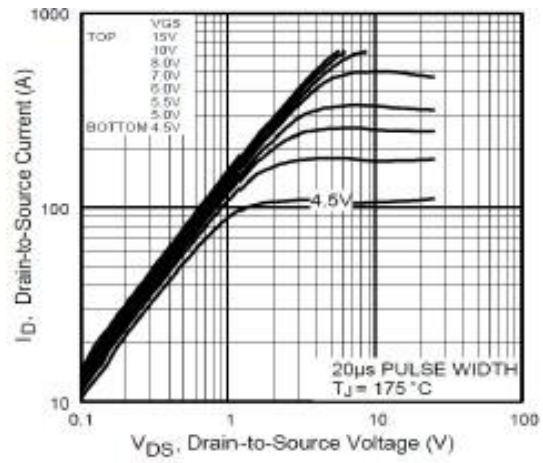

Fig 2. Typical Output Characteristics

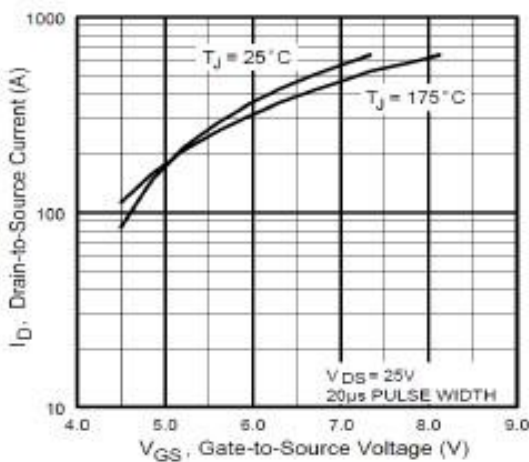

Fig 3. Typical Transfer Characteristics

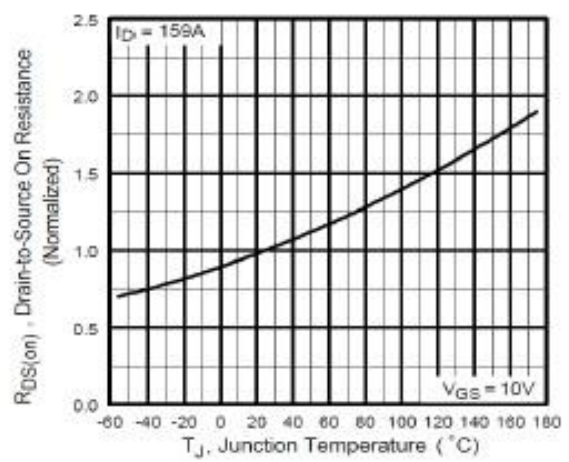

Fig 4. Normalized On-Resistance Vs. Temperature

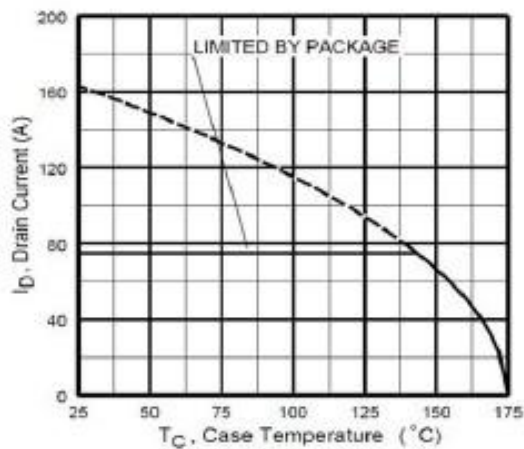

Fig 5. Maximum Drain Current Vs. Case Temperature

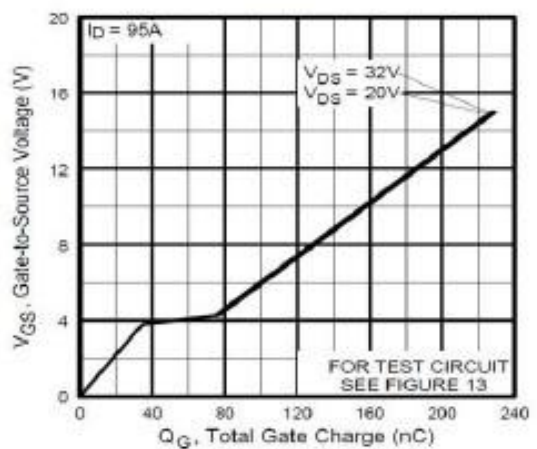

Fig 6. Typical Gate Charge Vs. Gate-to-Source Voltage



40V N-Channel MOSFET

Typical Characteristics $T_J = 25^\circ\text{C}$, unless otherwise noted

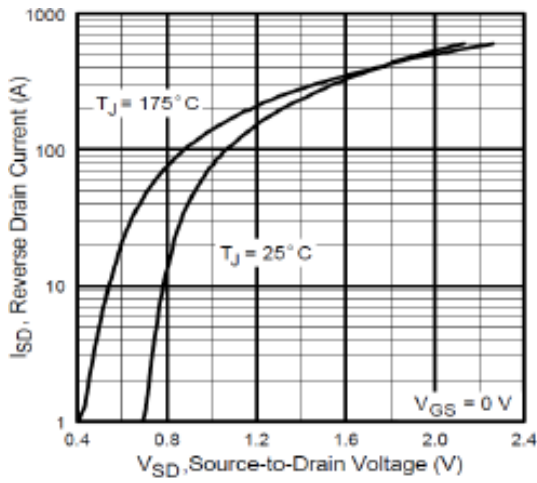

Fig 7. Typical Source-Drain Diode Forward Voltage

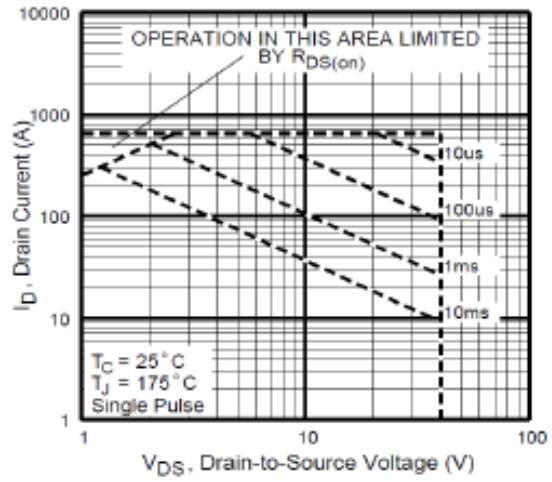

Fig 8. Maximum Safe Operating Area



40V N-Channel MOSFET

Figure A: Gate Charge Test Circuit and Waveform

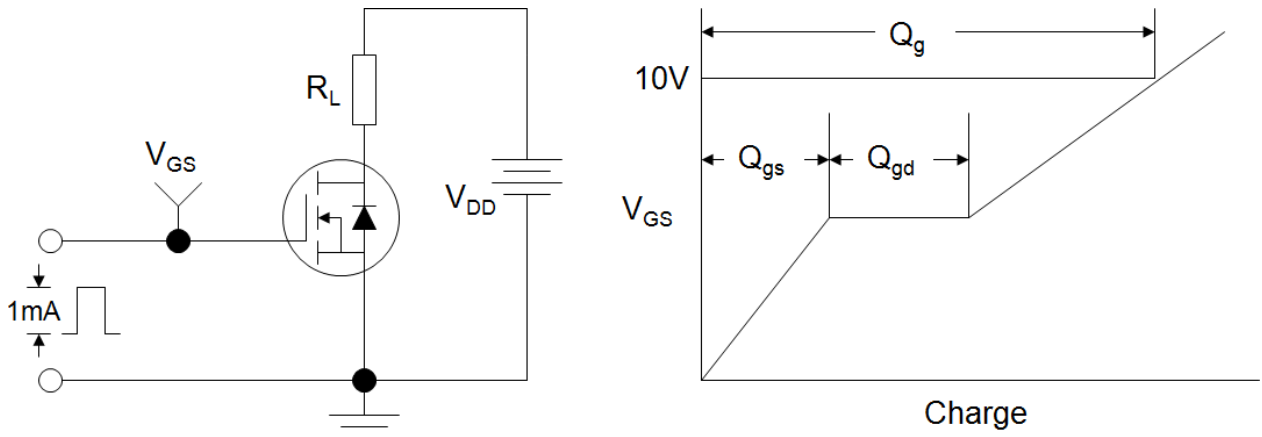

Figure B: Resistive Switching Test Circuit and Waveform

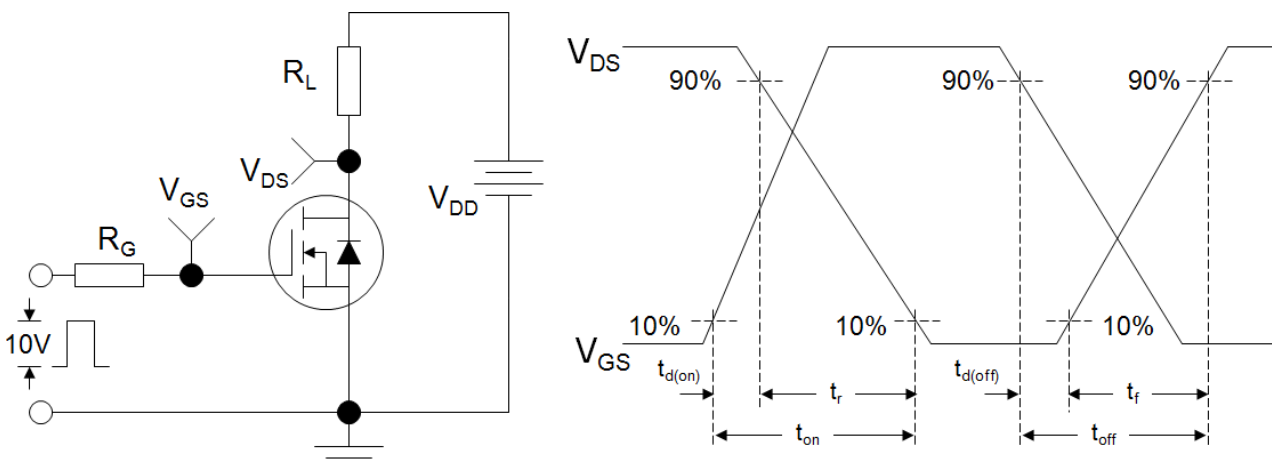
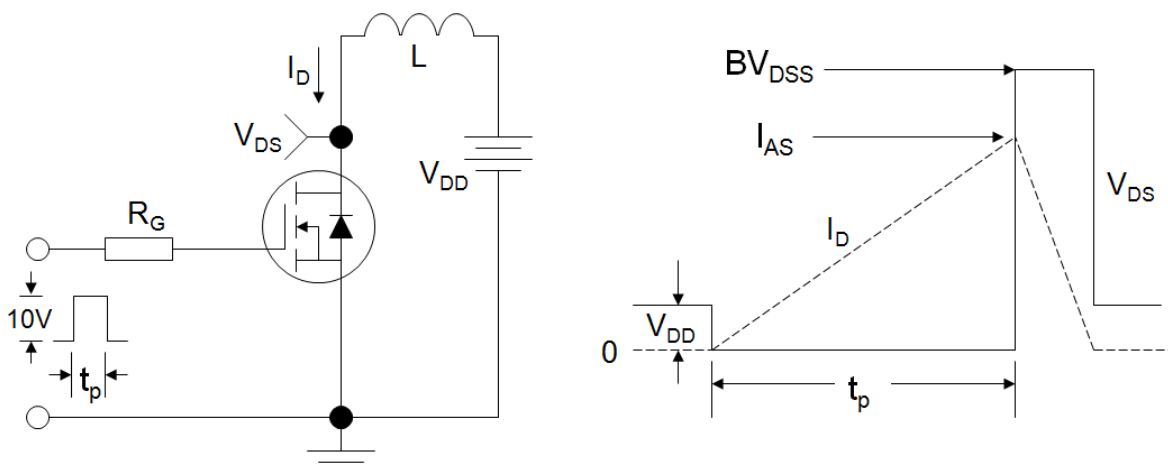
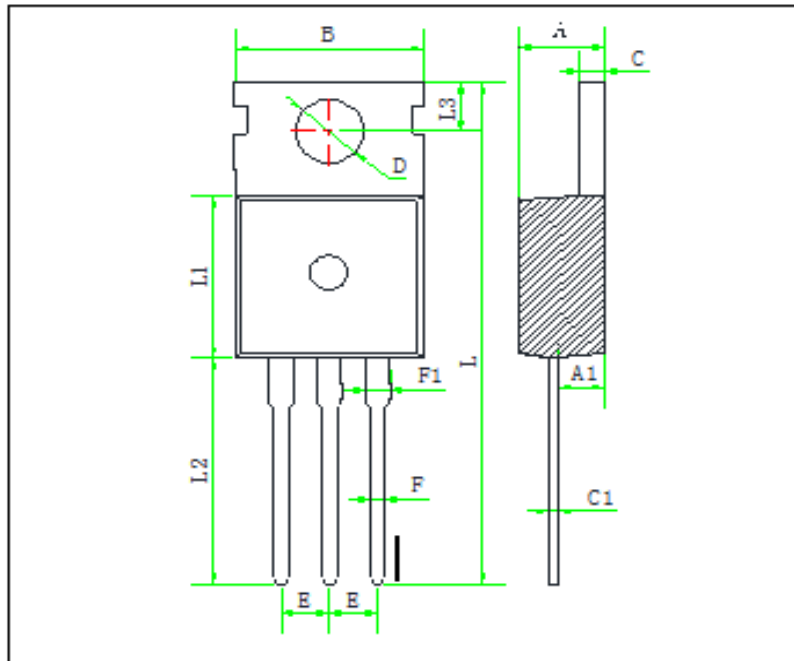

Figure C: Unclamped Inductive Switching Test Circuit and Waveform





40V N-Channel MOSFET



Symbol	Min	Typ	Max
A	4.43	4.53	4.63
A1	2.30	2.40	2.50
B	9.90	10.0	10.10
C	1.25	1.30	1.40
C1	0.45	0.50	0.60
D	3.50	3.60	3.70
E	2.44	2.54	2.64
F	0.70	0.80	0.95
F1	1.20	1.35	1.50
L	26.80	28.80	30.80
L1	9.20	9.30	9.40
L2	12.90	13.10	13.30
L3	2.70	2.80	2.90