

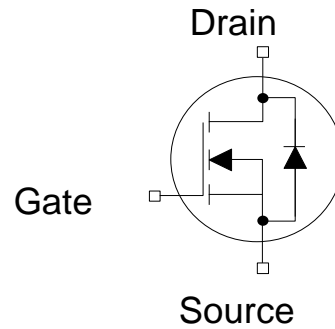

Description

WLP10N65 is high voltage MOSFET family based on advanced planar stripe DMOS technology. This advanced MOSFET family has optimized on-state resistance, and also provides superior switching performance and higher avalanche energy strength. This device family is suitable for high efficiency switch mode power supplies.



Features

- $R_{DS(on)} \leq 1\Omega$ @ $V_{gs}=10V, I_d=5A$
- Ultra Low gate Charge (typical 33.4nC)
- Low C_{rss} (typical 1.04pF)
- Fast switching capability
- 100% avalanche tested
- Improved dv/dt capability

Applications

- Switch Mode Power Supply (SMPS)
- Uninterruptible Power Supply (UPS)
- Power Factor Correction (PFC) (PFC)
- Charger

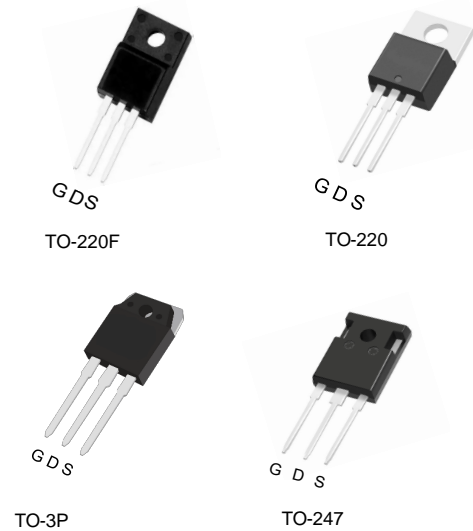

Key Performance Parameters

Parameter	Value	Unit
$V_{DS} @ T_{j,max}$	700	V
$R_{DS(on),max}$	1	Ω
$Q_{g,typ}$	33.4	nC
I_D	10	A
$I_{D,pulse}$	40	A

Device Marking and Package Information

Device	Package	Marking
WLP10N65F	TO-220F	10N65F
WLP10N65	TO-220	10N65
WLP10N65G	TO-3P	10N65G
WLP10N65E	TO-247	10N65E



Absolute Maximum Ratings $T_C = 25^\circ\text{C}$, unless otherwise noted			
Parameter	Symbol	Value	Unit
Drain-Source Voltage($V_{GS}=0\text{V}$)	V_{DS}	650	V
Continuous Drain Current ¹⁾	I_D	$T_C = 25^\circ\text{C}$	10
		$T_C = 100^\circ\text{C}$	6.5
Pulsed Drain Current ²⁾	$I_{D,pulse}$	40	A
Gate-Source Voltage	V_{GS}	± 30	V
Single Pulse Avalanche Energy ³⁾	E_{AS}	245	mJ
MOSFET dv/dt Ruggedness, $V_{DS} = 0\dots 480\text{V}$	dv/dt	5	V/ns
Power Dissipation For TO-220F	P_D	93	W
Power Dissipation For TO-220/3P/247		120	
Continuous Diode Forward Current	I_S	10	A
Diode Pulsed Current ²⁾	$I_{S,pulse}$	40	
Operating Junction and Storage Temperature Range	T_J, T_{stg}	-55~+150	$^\circ\text{C}$

Thermal Resistance For TO-220F			
Parameter	Symbol	Value	Unit
Thermal Resistance, Junction-to-Case	R_{thJC}	1.34	$^\circ\text{C}/\text{W}$
Thermal Resistance, Junction-to-Ambient	R_{thJA}	80	

Thermal Resistance For TO-220/3P/247			
Parameter	Symbol	Value	Unit
Thermal Resistance, Junction-to-Case	R_{thJC}	1.04	$^\circ\text{C}/\text{W}$
Thermal Resistance, Junction-to-Ambient	R_{thJA}	62	

Notes

- 1) Limited by maximum junction temperature.
- 2) Repetitive Rating: Pulse width limited by maximum junction temperature.
- 3) $L=10\text{mH}$, $I_D=7\text{A}$, Start $T_J=25^\circ\text{C}$



Electrical Characteristics $T_J = 25^\circ\text{C}$, unless otherwise noted						
Parameter	Symbol	Test Conditions	Value			Unit
			Min.	Typ.	Max.	
Static Characteristics						
Drain-Source Breakdown Voltage	$V_{(BR)DSS}$	$V_{GS} = 0V, I_D = 250\mu A$	650	--	--	V
Zero Gate Voltage Drain Current	I_{DSS}	$V_{DS} = 650V$ $V_{GS} = 0V, T_J = 25^\circ\text{C}$	--	--	1	μA
		$V_{DS} = 650V$, $V_{GS} = 0V, T_J = 150^\circ\text{C}$	--	--	100	
Gate-Source Leakage Current	I_{GSS}	$V_{GS} = \pm 30V$	--	--	± 100	nA
Gate-Source Threshold Voltage	$V_{GS(th)}$	$V_{DS} = V_{GS}, I_D = 250\mu A$	3	--	5	V
Drain-Source On-State-Resistance	$R_{DS(on)}$	$V_{GS} = 10V, I_D = 5A$	--	0.8	1.0	Ω
Gate Resistance	R_G	$f = 1.0\text{MHz}$ open drain	--	2	--	Ω
Dynamic Characteristics						
Input Capacitance	C_{iss}	$V_{GS} = 0V, V_{DS} = 25V$ $f = 1.0\text{MHz}$	--	1983	--	μF
Output Capacitance	C_{oss}		--	89	--	
Reverse Transfer Capacitance	C_{rss}		--	1	--	
Total Gate Charge	Q_g	$V_{DD} = 520V, I_D = 10A$ $V_{GS} = 10V$	--	33	--	nC
Gate-Source Charge	Q_{gs}		--	13.2	--	
Gate-Drain Charge	Q_{gd}		--	8.8	--	
Gate Plateau Voltage	$V_{Plateau}$		--	6.2	--	V
Turn-on Delay Time	$t_{d(on)}$	$V_{DD} = 250V, I_D = 10A$ $R_G = 25\Omega, V_{GS} = 10V$	--	38	--	ns
Turn-on Rise Time	t_r		--	67	--	
Turn-off Delay Time	$t_{d(off)}$		--	55	--	
Turn-off Fall Time	t_f		--	32	--	
Drain-Source Body Diode Characteristics						
Body Diode Forward Voltage	V_{SD}	$T_J = 25^\circ\text{C}, I_{SD} = 10A$ $V_{GS} = 0V$	--	--	1.2	V
Reverse Recovery Time	t_{rr}	$V_R = 400V$ $I_F = 10A, di_F/dt = 100A/\mu s$	--	730	--	ns
Reverse Recovery Charge	Q_{rr}		--	9.5	--	μC



Typical Characteristics $T_J = 25^\circ\text{C}$, unless otherwise noted

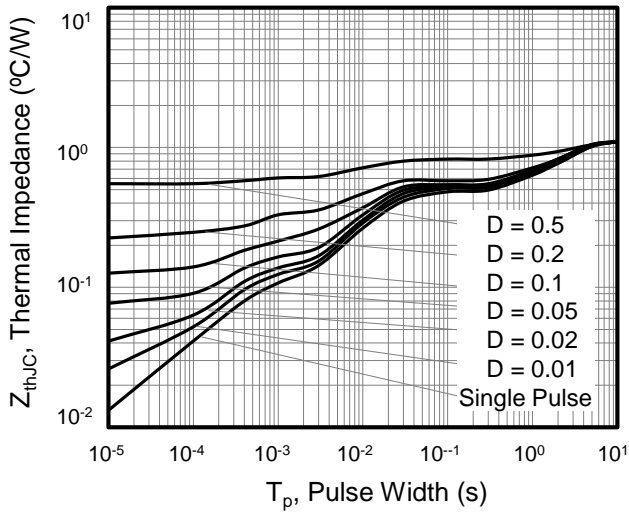

Figure 1. Transient Thermal Impedance For TO-220F

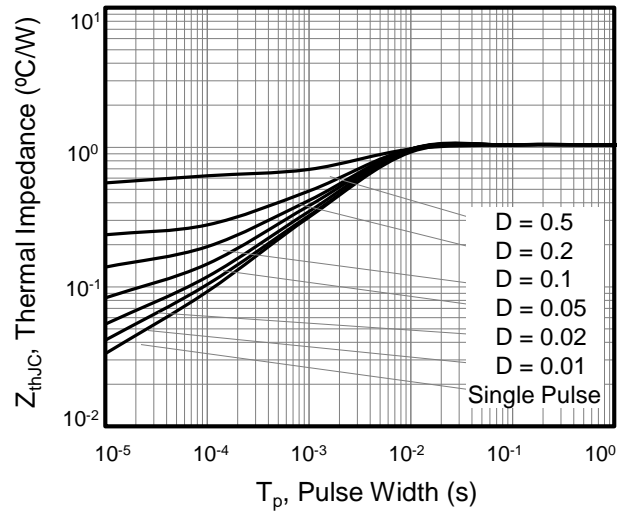

Figure 2. Transient Thermal Impedance For TO-220/3P/247

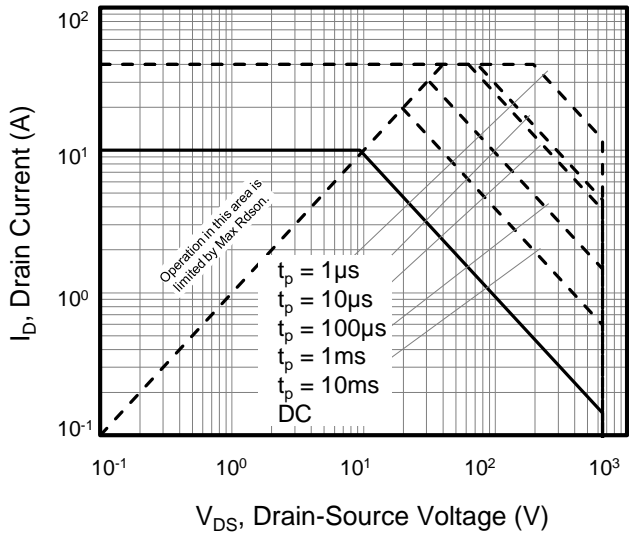

Figure 3. Safe Operation Area For TO-220F

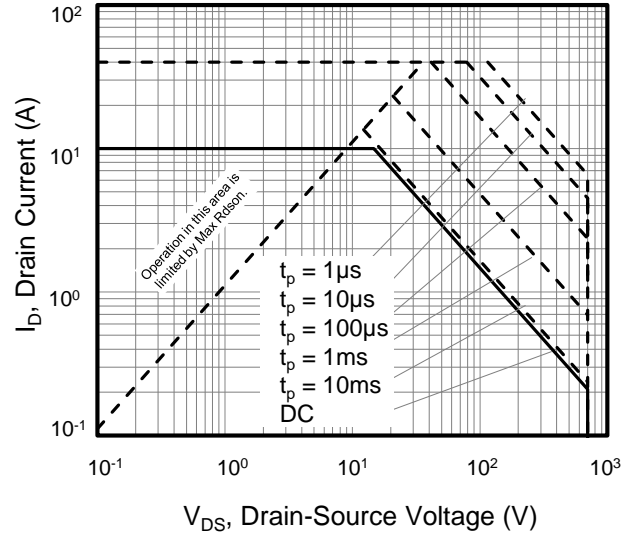

Figure 4. Safe Operation Area For TO-220/3P/247

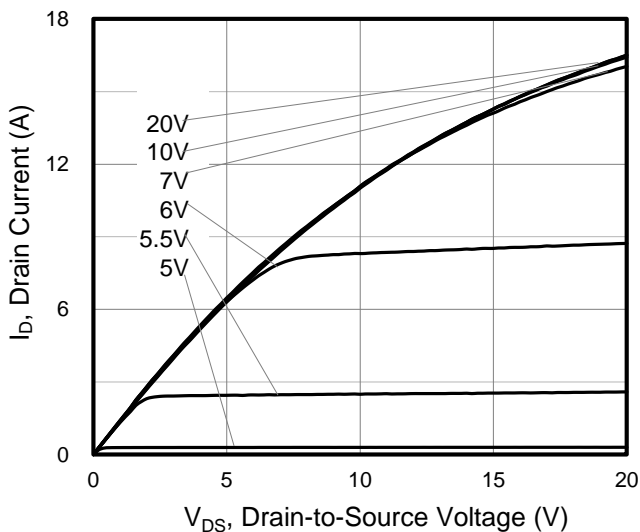

Figure 5. Output Characteristics

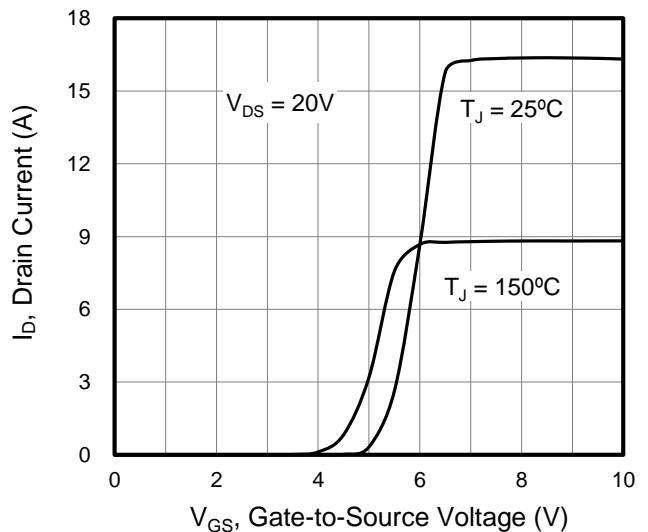

Figure 6. Transfer Characteristics



Typical Characteristics $T_J = 25^\circ\text{C}$, unless otherwise noted

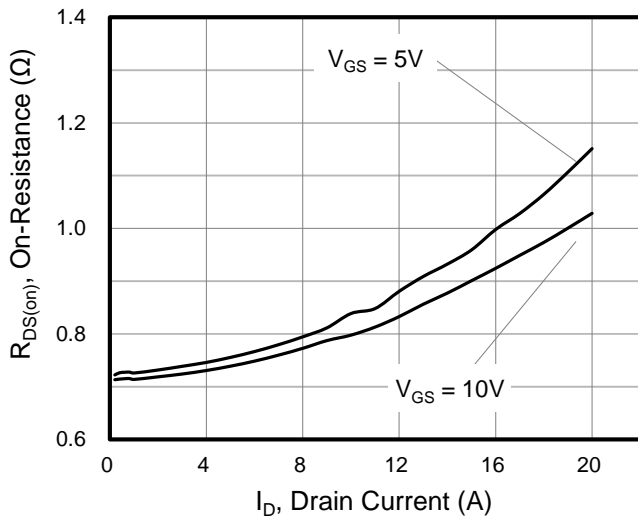

Figure 7. On-Resistance vs Drain Current

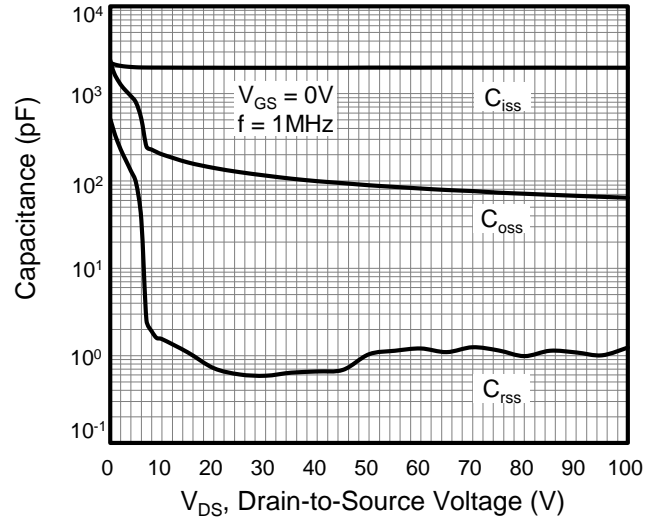

Figure 8. Capacitance

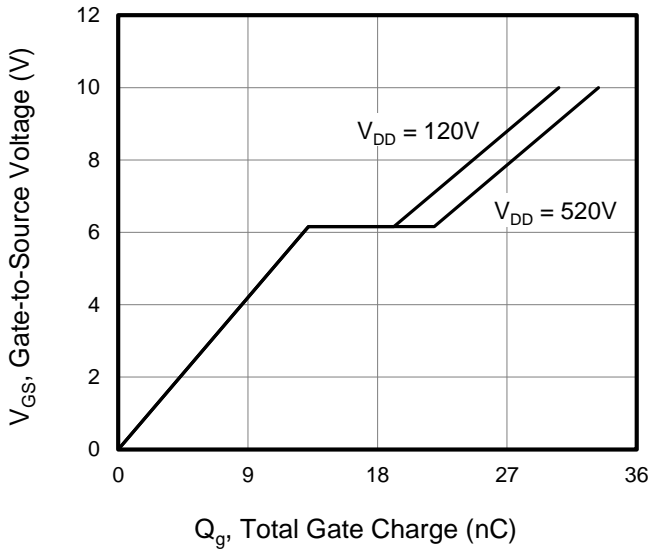

Figure 9. Gate Charge

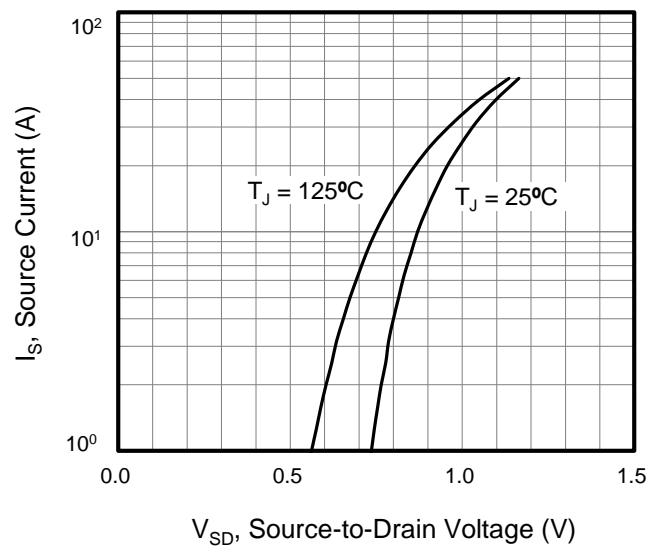

Figure 10. Body Diode Forward Voltage

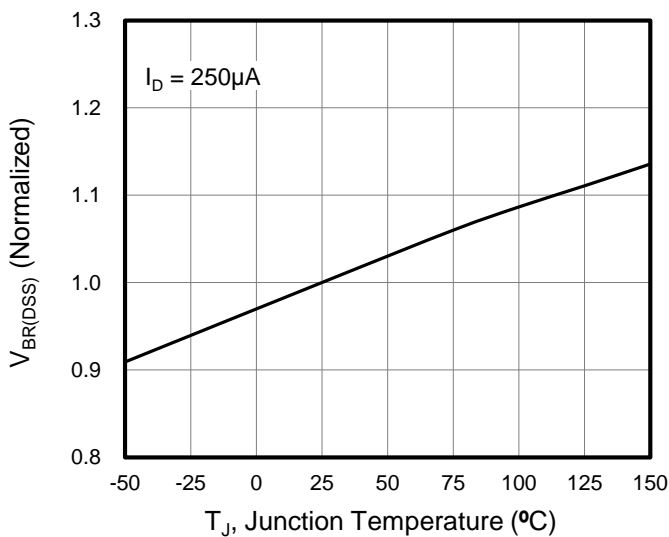

Figure 11. Breakdown Voltage vs Junction Temperature

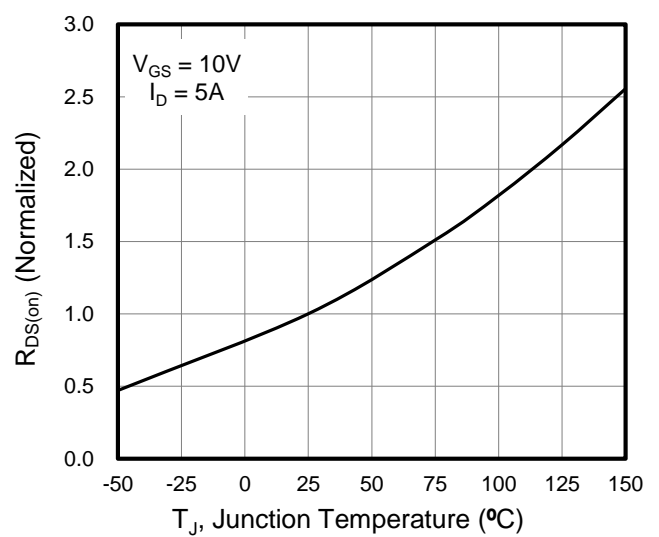

Figure 12. On-Resistance vs Temperature



Figure A: Gate Charge Test Circuit and Waveform

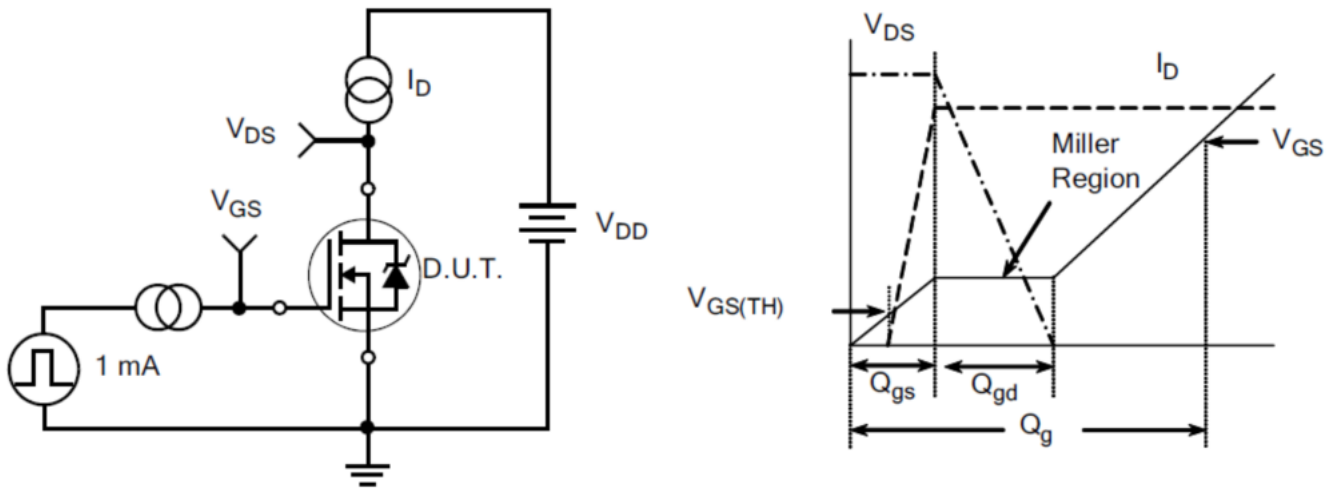

Figure B: Resistive Switching Test Circuit and Waveform

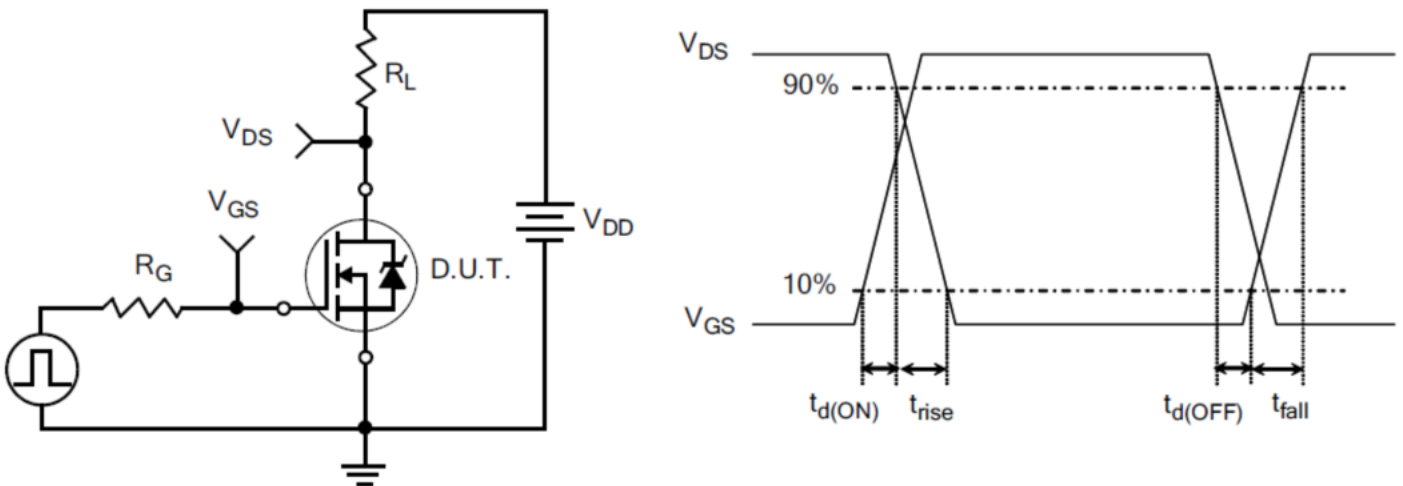
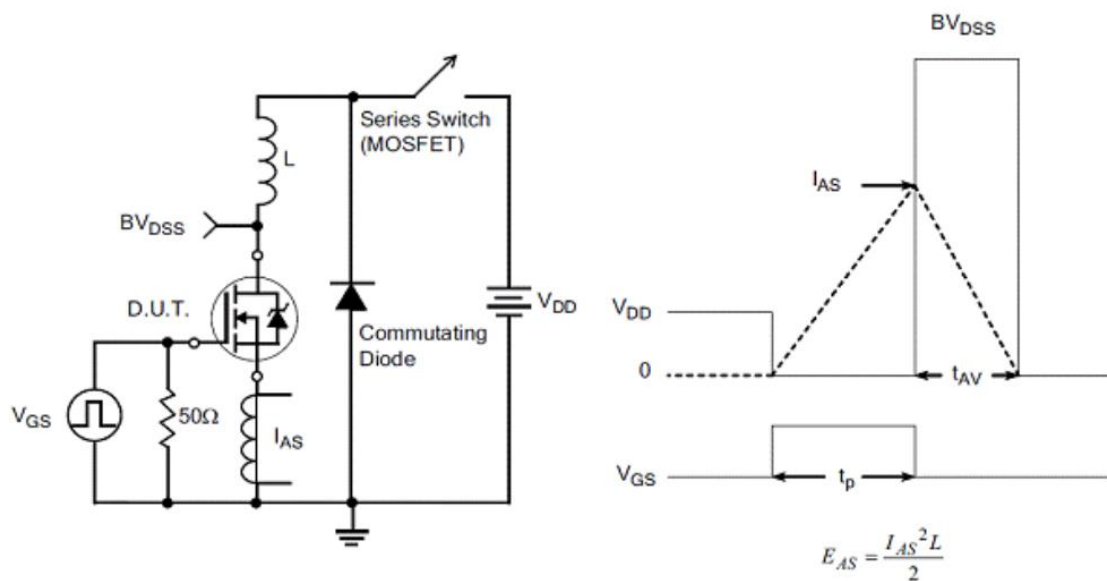
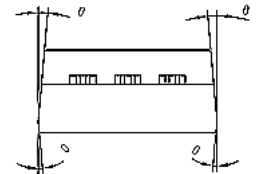
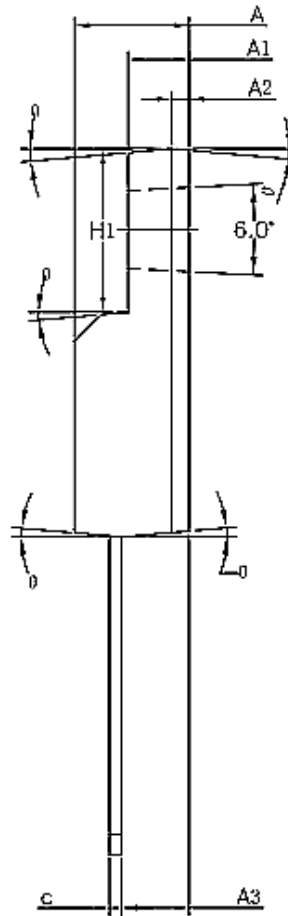
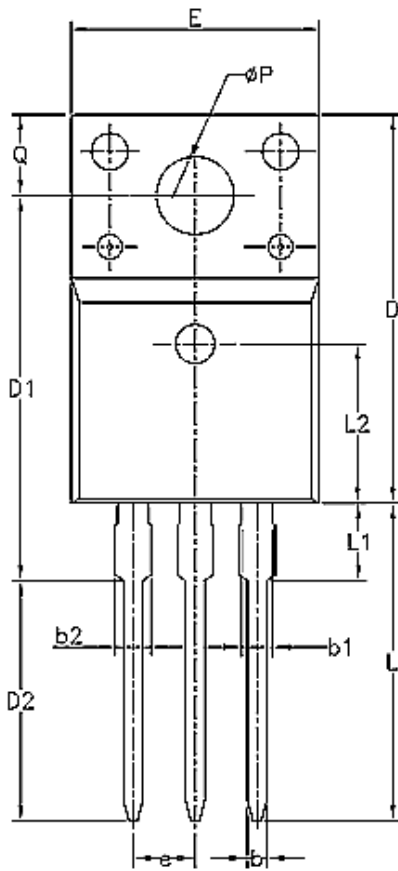

Figure C: Unclamped Inductive Switching Test Circuit and Waveform





Outlines TO-220F Package



Unit:mm			
Symbol	Min.	Nom	Max.
A	4.50	4.70	4.83
A1	2.34	2.54	2.74
A2	0.70 REF		
A3	2.56	2.76	2.93
b	0.70	---	0.90
b1	1.18	---	1.38
b2	---	---	1.47
c	0.45	0.50	0.60
D	15.67	15.87	16.07
D1	15.55	15.75	15.95

Unit:mm			
Symbol	Min.	Nom	Max.
D2	9.60	9.80	10.0
E	9.96	10.16	10.36
e	2.54 BSC		
H1	6.48	6.68	6.88
L	12.68	12.98	13.28
L1	---	---	3.50
L2	6.50 REF		
ΦP	3.08	3.18	3.28
Q	3.20	---	3.40
θ1	1°	3°	5°



Outlines TO-220 Package

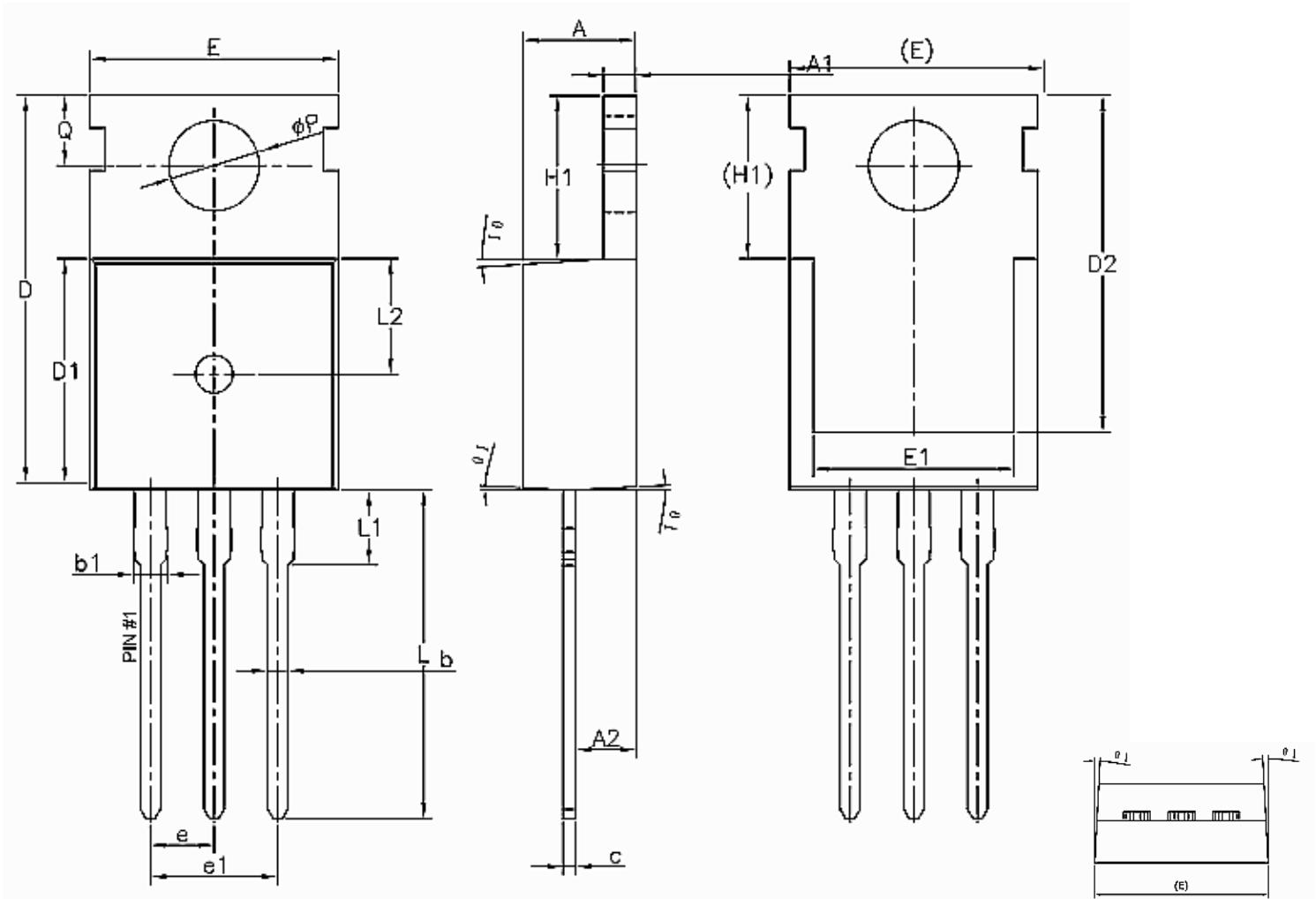

Unit:mm			
Symbol	Min.	Nom	Max.
A	4.40	4.50	4.60
A1	1.27	1.30	1.33
A2	2.30	2.40	2.50
b	0.70	---	0.90
b2	1.27	---	1.40
c	0.45	0.50	0.60
D	15.30	15.70	16.10
D1	9.10	9.20	9.30
D2	13.10	---	13.70
E	9.70	9.90	10.20

Unit:mm			
Symbol	Min.	Nom	Max.
E1	7.80	8.00	8.20
e	2.54 BSC		
e1	5.08 BSC		
H1	6.30	6.50	6.70
L	12.78	13.08	13.38
L1	---	---	3.50
L2	4.60 REF		
φP	3.55	3.60	3.65
Q	2.73	---	2.87
θ1	1°	3°	5°



Outlines TO-3P Package

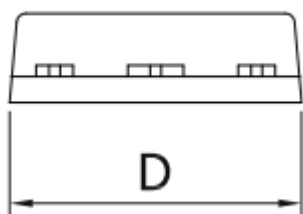
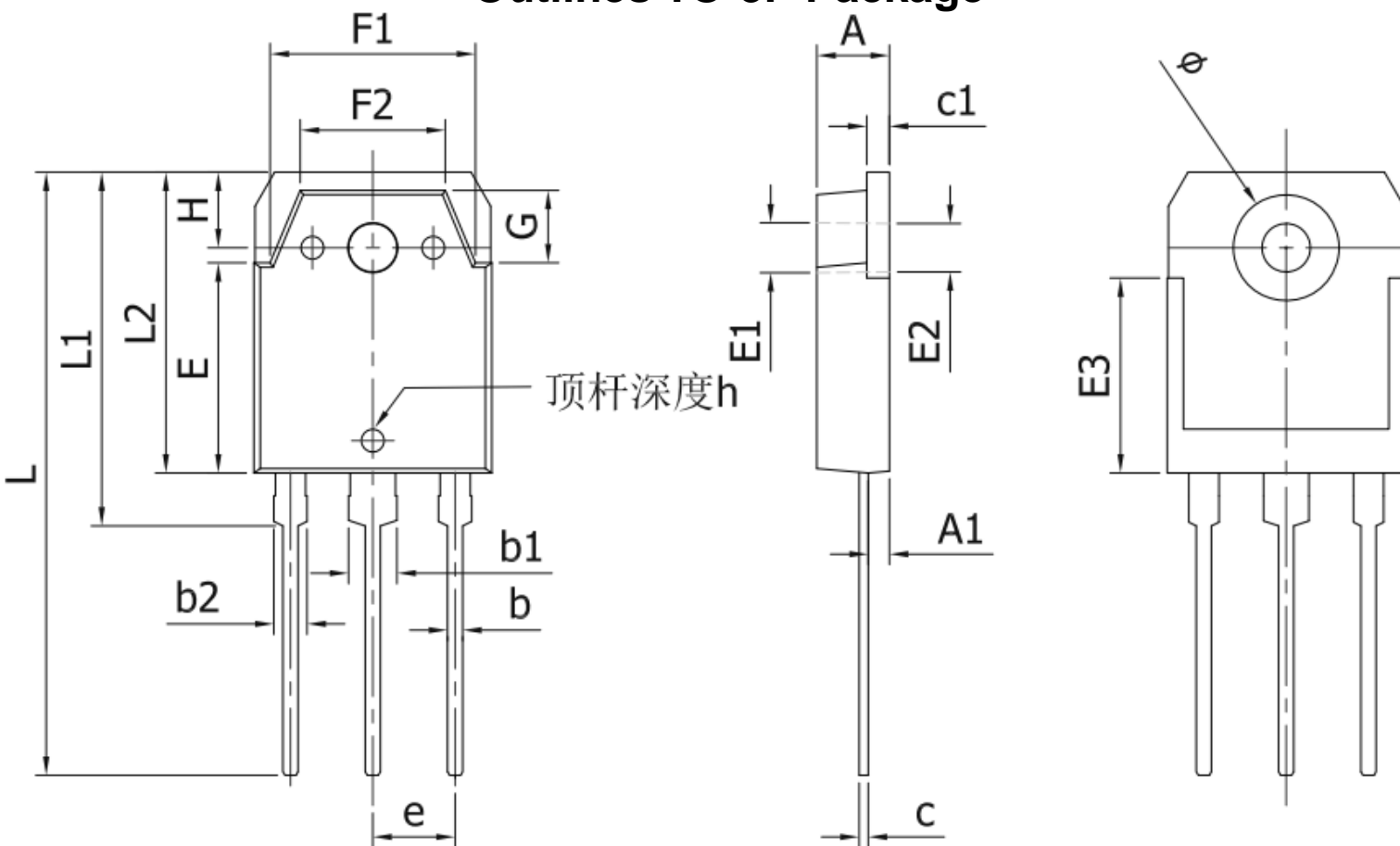

SYMBOL	MIN	NOM	MAX
A	4.6	4.8	5.0
A1	1.2	1.4	1.6
b	0.8	1	1.2
b1	2.8	3	3.2
b2	1.8	2	2.2
c	0.5	0.6	0.7
c1	1.45	1.55	1.65
D	15.45	15.65	15.85
E	13.7	13.9	14.1
E1	3.3REF		
E2	3.2REF		

SYMBOL	MIN	NOM	MAX
E3	12.9REF		
F1	13.4	13.6	13.8
F2	9.4	9.6	9.8
L	39.7	39.9	40.1
L1	23.2	23.4	23.6
L2	19.7	19.9	20.1
ø	6.9	7	7.1
G	4.6	4.8	5.0
e	5.45TYP		
H	5.0REF		
h	0.0	0.15	0.3



Outlines TO-247 Package

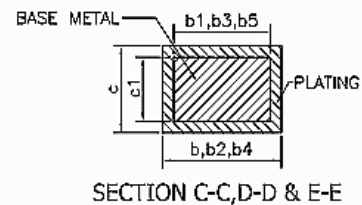
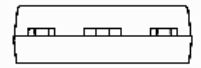
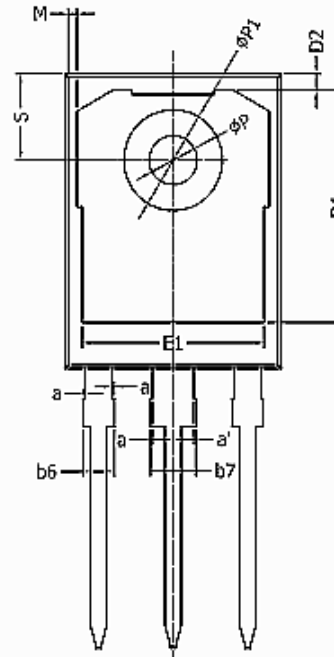
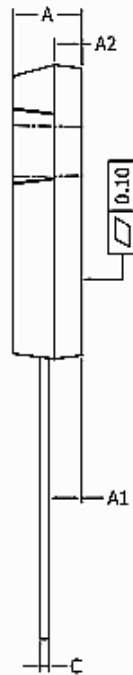
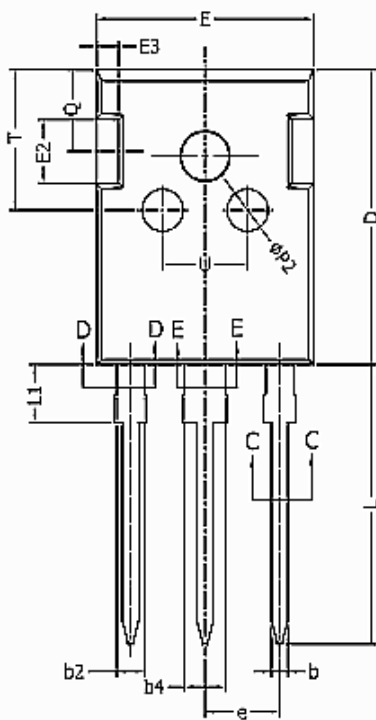

SYMBOL	MIN	NOM	MAX
A	4.9	5	5.1
A1	2.31	2.41	2.51
A2	1.9	2	2.1
a	0	---	0.15
a'	0	---	0.15
b	1.16	---	1.26
b1	1.15	1.2	1.22
b2	1.96	---	2.06
b3	1.95	2	2.02
b4	2.96	---	3.06
b5	2.96	3	3.02
b6	---	---	2.25
b7	---	---	3.25
c	0.59	---	0.66
c1	0.58	0.6	0.62
D	20.9	21	21.1
D1	16.25	16.55	16.85

SYMBOL	MIN	NOM	MAX
D2	1.05	1.17	1.35
E	15.7	15.8	15.9
E1	13.1	13.3	13.5
E2	4.4	4.5	4.6
E3	2.4	2.5	2.6
e	5.436 BSC		
L	19.8	19.92	20.1
L1	---	---	4.3
M	0.35	---	0.95
P	3.4	3.5	3.6
P1	7	---	7.4
P2	2.4	2.5	2.6
Q	5.6	---	6
S	6.05	6.15	6.25
T	9.8	---	10.2
U	6	---	6.4



Disclaimer

Brunei has made reasonable commercial efforts to ensure that the information given in this datasheet is correct. However, it must clearly be understood that such information is for guidance only and does not constitute any representation or form part of any offer or contract.

For documents and material available from this datasheet, Brunei does not warrant or assume any legal liability or responsibility for the accuracy, completeness, or usefulness of any information, product, technology or process disclosed hereunder.

Brunei reserves the rights to at its own discretion to make any changes or improvements to this datasheet. Unless said datasheet is incorporated into the formal contract, any customer should not rely on the information as any specification or product parameters duly committed by Brunei Customers are hereby advised to verify that the information contained herein is current and complete before the entering of any contract or acknowledgement of any purchase order. Accordingly, all products specified hereunder shall be sold subject to Brunei's terms and conditions supplied at the time of order acknowledgement. Except where agreed upon by contractual agreement, testing of all parameters of each product is not necessarily performed.

Brunei does not warrant or convey any license either expressed or implied under its patent rights, nor the rights of others. Reproduction of information contained herein shall be only permissible if such reproduction is without any modification or alteration. Reproduction of this information with any alteration is an unfair and deceptive business practice. Brunei is not responsible or liable for such altered documentation.

Resale of Brunei's products with statements different from or beyond the parameters stated by Brunei for that product or service voids all express or implied warranties for the associated Brunei's product or service and is unfair and deceptive business practice. Brunei is not responsible or liable for any such statements.

Brunei's products are not authorized for use as critical components in life support devices or systems without the express written approval of Brunei. As used herein:

1. Life support devices or systems are devices or systems which, (a) are intended for surgical implant into the body, or (b) support or sustain life, and whose failure to perform, when properly used in accordance with instructions for use provided in the labeling, can be reasonably expected to result in a significant injury to the user.
2. A critical component is any component of a life support device or system whose failure to perform can be reasonably expected to cause the failure of the life support device or system, or to affect its safety or effectiveness.