



Feature

- ◇ High Speed Power Smooth Switching
- ◇ Enhanced Body diode dv/dt capability
- ◇ Enhanced Avalanche Ruggedness
- ◇ 100% UIS Tested, 100% Rg Tested
- ◇ Lead Free

Application

- ◇ Synchronous Rectification in SMPS
- ◇ Hard Switching and High Speed Circuit
- ◇ Power Tools
- ◇ UPS
- ◇ Motor Control

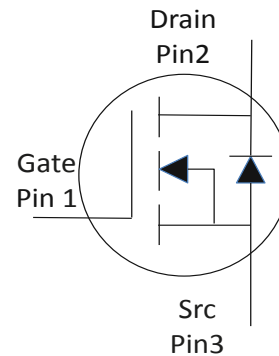

V_{DS}		250	V
$R_{DS(on),typ}$	TO-263	16.3	m Ω
$R_{DS(on),typ}$	TO-247	15.5	m Ω
$R_{DS(on),typ}$	TO-220	16.6	m Ω
I_D (Silicon Limited)		93	A
I_D (Package Limited)		180	A



Absolute Maximum Ratings at $T_j=25^\circ\text{C}$ (unless otherwise specified)

Parameter	Symbol	Conditions	Value	Unit
Continuous Drain Current (Silicon Limited)	I_D	$T_C=25^\circ\text{C}$	93	A
		$T_C=100^\circ\text{C}$	66	
Drain to Source Voltage	V_{DS}	-	250	V
Gate to Source Voltage	V_{GS}	-	± 20	V
Pulsed Drain Current	I_{DM}	-	290	A
Avalanche Energy, Single Pulse	E_{AS}	$L=0.4\text{mH}, T_C=25^\circ\text{C}$	180	mJ
Power Dissipation	P_D	$T_C=25^\circ\text{C}$	429	W
Operating and Storage Temperature	T_J, T_{stg}	-	-55 to 175	$^\circ\text{C}$

Absolute Maximum Ratings

Parameter	Symbol	Max	Unit
Thermal Resistance Junction-Case	$R_{\theta JC}$	0.35	$^\circ\text{C}/\text{W}$
Thermal Resistance Junction-Ambient	$R_{\theta JA}$	60	$^\circ\text{C}/\text{W}$



Electrical Characteristics at $T_J=25^\circ\text{C}$ (unless otherwise specified)

Static Characteristics							
Parameter	Symbol	Conditions	Value			Unit	
			min	typ	max		
Drain to Source Breakdown Voltage	$V_{(BR)DSS}$	$V_{GS}=0V, I_D=250\mu A$	250	-	-	V	
Gate Threshold Voltage	$V_{GS(th)}$	$V_{GS}=V_{DS}, I_D=250\mu A$	2	3	4		
Zero Gate Voltage Drain Current	I_{DSS}	$V_{GS}=0V, V_{DS}=200V, T_J=25^\circ\text{C}$	-	-	1	μA	
		$V_{GS}=0V, V_{DS}=200V, T_J=100^\circ\text{C}$	-	-	100		
Gate to Source Leakage Current	I_{GSS}	$V_{GS}=\pm 20V, V_{DS}=0V$	-	-	± 100	nA	
Drain to Source on Resistance	$R_{DS(on)}$	$V_{GS}=10V, I_D=20A$	TO-263	-	16.3	21.7	m Ω
			TO-247	-	15.5	21.9	
			TO-220	-	16.6	22	
Transconductance	g_{fs}	$V_{DS}=5V, I_D=20A$	-	70	-	S	
Gate Resistance	R_G	$V_{GS}=0V, V_{DS}$ Open, $f=1\text{MHz}$	-	3.7	-	Ω	
Dynamic Characteristics							
Input Capacitance	C_{iss}	$V_{GS}=0V, V_{DS}=100V, f=1\text{MHz}$	-	4950	-	pF	
Output Capacitance	C_{oss}		-	348	-		
Reverse Transfer Capacitance	C_{rss}		-	7	-		
Total Gate Charge	Q_g	$V_{DD}=125V, I_D=20A, V_{GS}=10V$	-	58	-	nC	
Gate to Source Charge	Q_{gs}		-	18	-		
Gate to Drain (Miller) Charge	Q_{gd}		-	6	-		
Turn on Delay Time	$t_{d(on)}$	$V_{DD}=125V, I_D=20A, V_{GS}=10V, R_G=10\Omega,$	-	17	-	ns	
Rise time	t_r		-	22	-		
Turn off Delay Time	$t_{d(off)}$		-	38	-		
Fall Time	t_f		-	11	-		
Reverse Diode Characteristics							
Diode Forward Voltage	V_{SD}	$V_{GS}=0V, I_F=20A$	-	0.9	-	V	
Reverse Recovery Time	t_{rr}	$V_R=125V, I_F=20A, di_F/dt=100A/\mu s$	-	168	-	ns	
Reverse Recovery Charge	Q_{rr}		-	840	-	nC	



Fig 1. Typical Output Characteristics

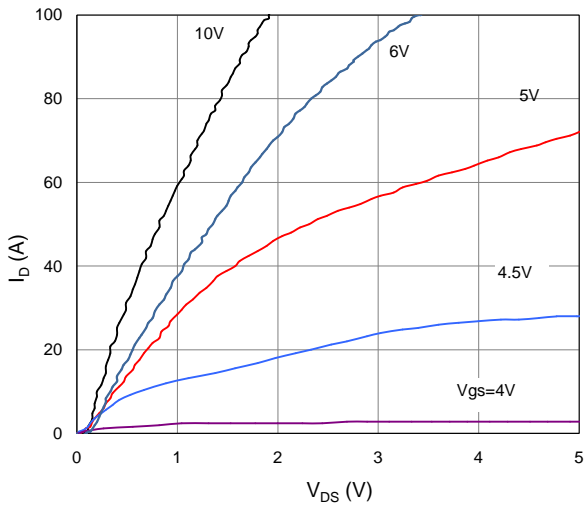

Figure 2. On-Resistance vs. Gate-Source Voltage

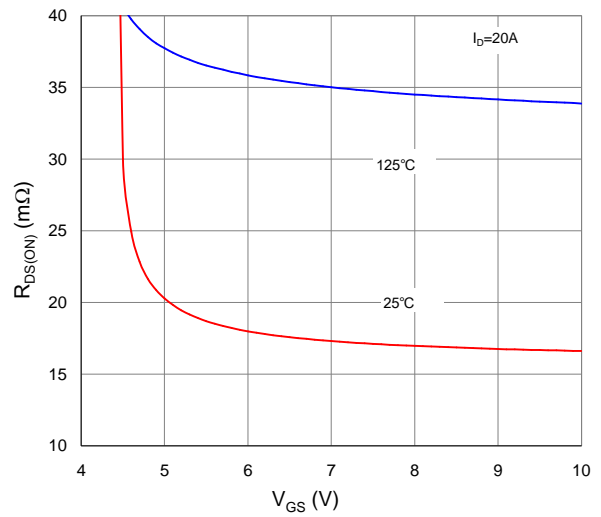

Figure 3. On-Resistance vs. Drain Current and Gate Voltage

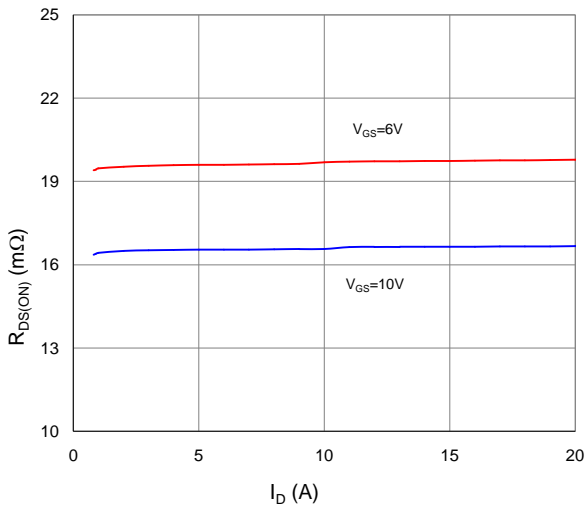

Figure 4. Normalized On-Resistance vs. Junction Temperature

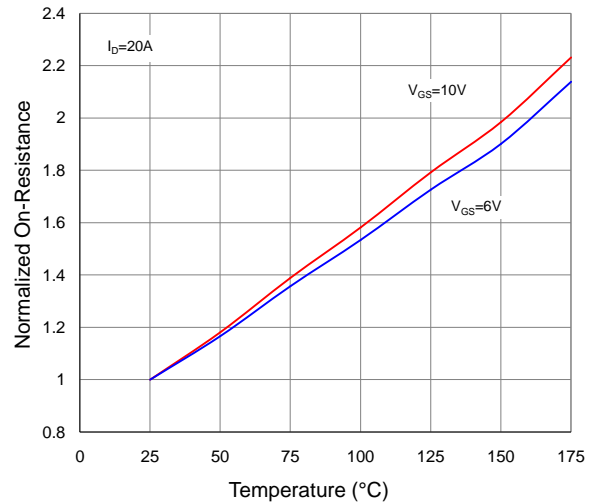

Figure 5. Typical Transfer Characteristics

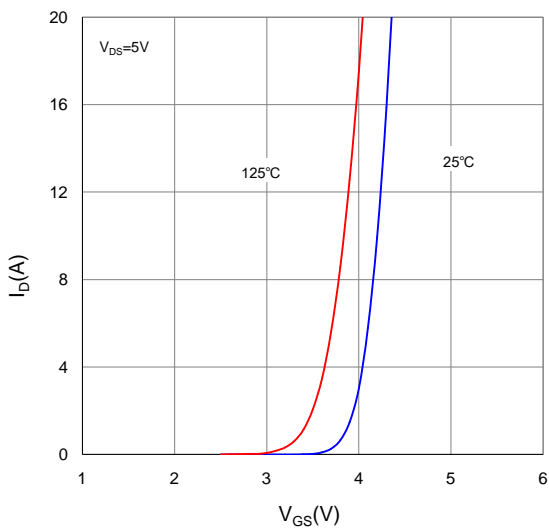

Figure 6. Typical Source-Drain Diode Forward Voltage

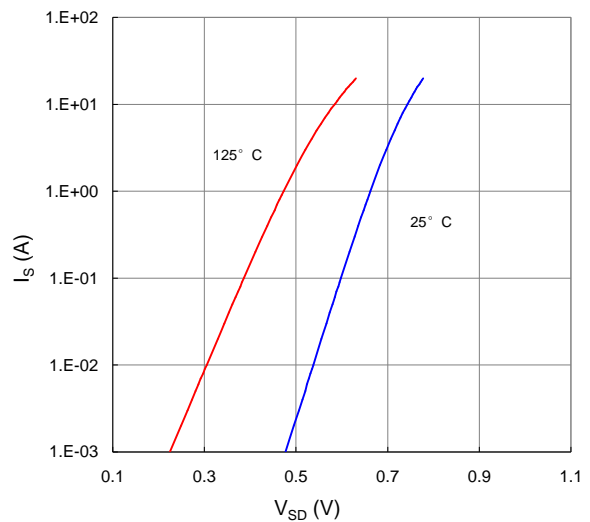



Figure 7. Typical Gate-Charge vs. Gate-to-Source Voltage

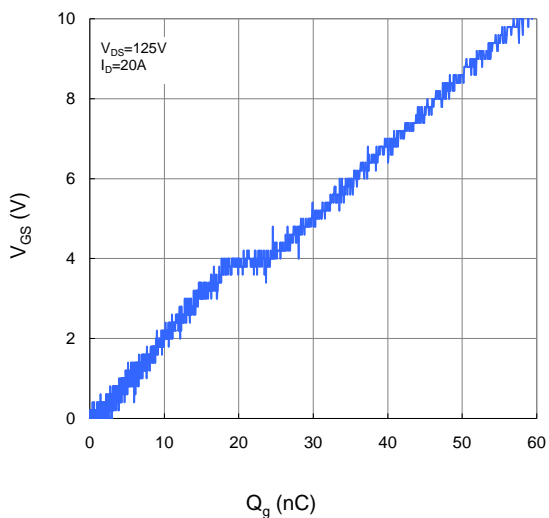

Figure 8. Typical Capacitance vs. Drain-to-Source Voltage

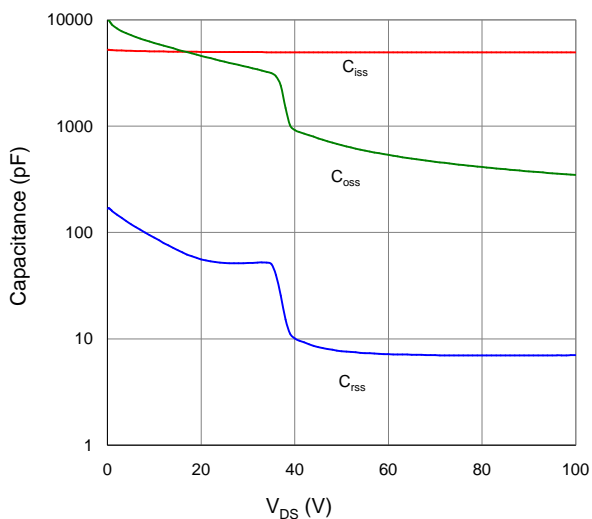

Figure 9. Maximum Safe Operating Area

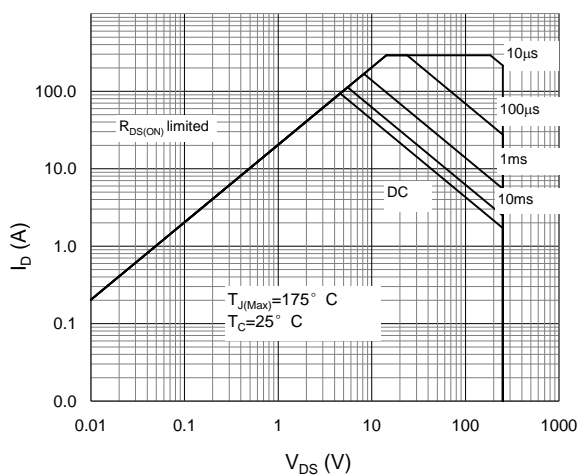

Figure 10. Maximum Drain Current vs. Case Temperature

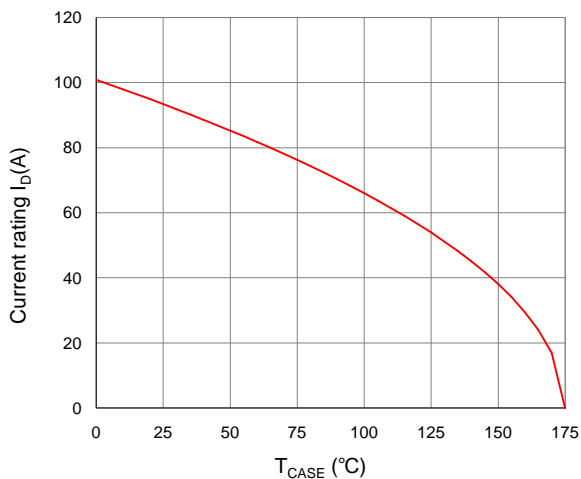
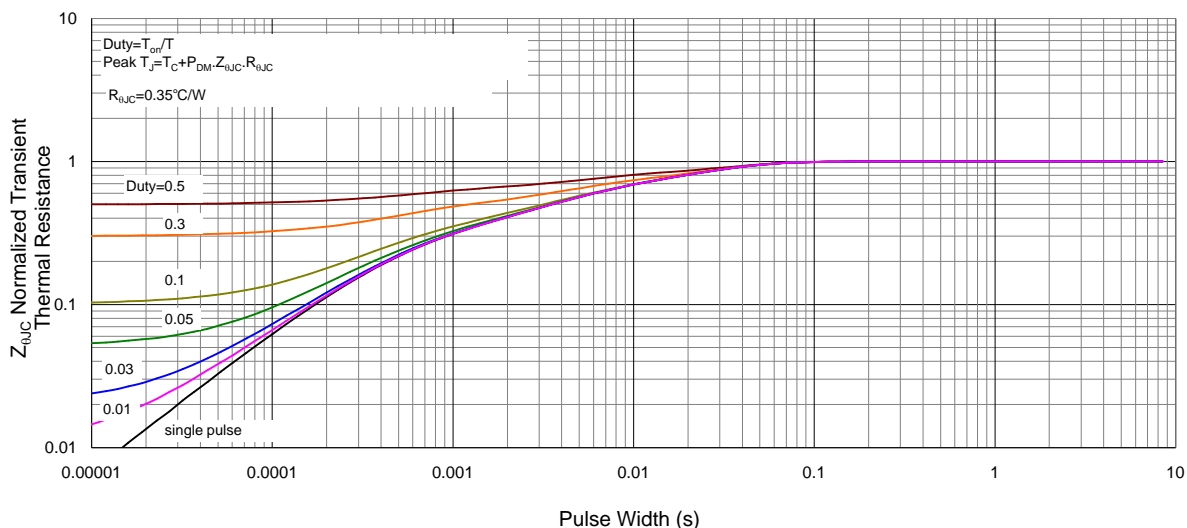
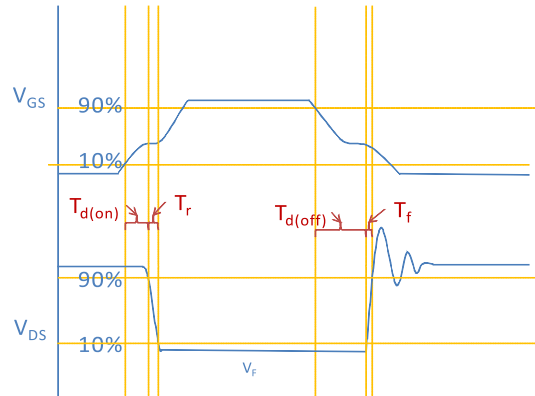
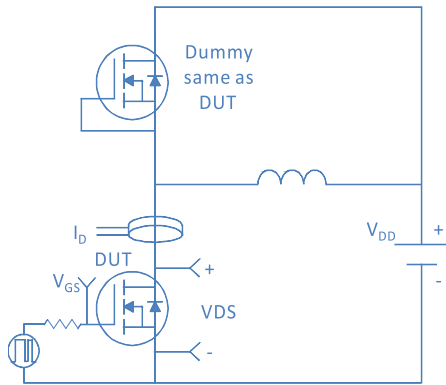

Figure 11. Normalized Maximum Transient Thermal Impedance, Junction-to-Case





Inductive switching Test



Gate Charge Test

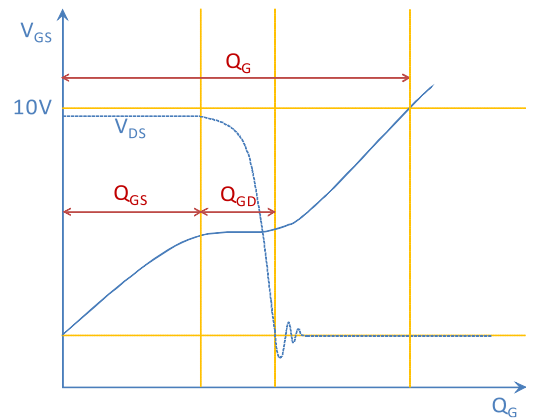
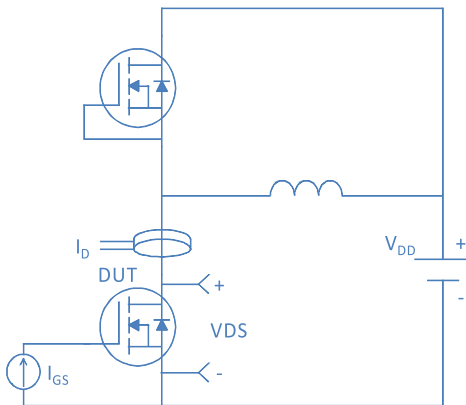

Uclamped Inductive Switching (UIS) Test

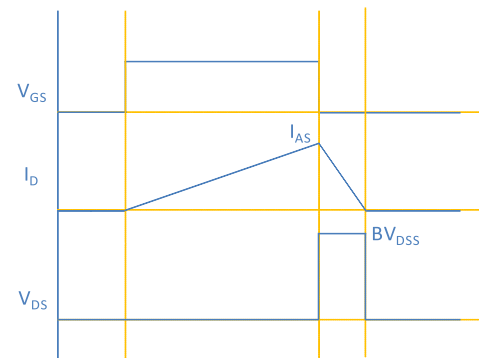
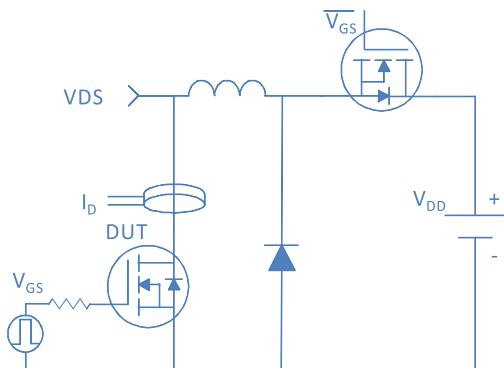

Diode Recovery Test

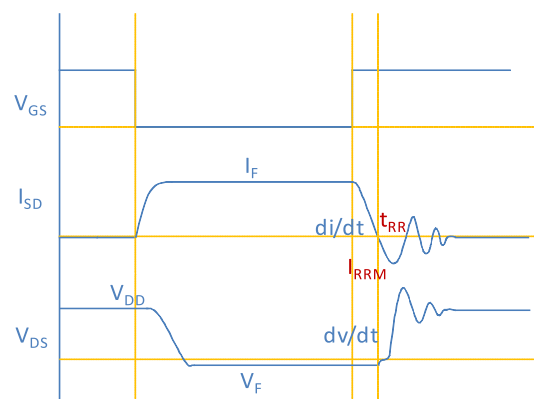
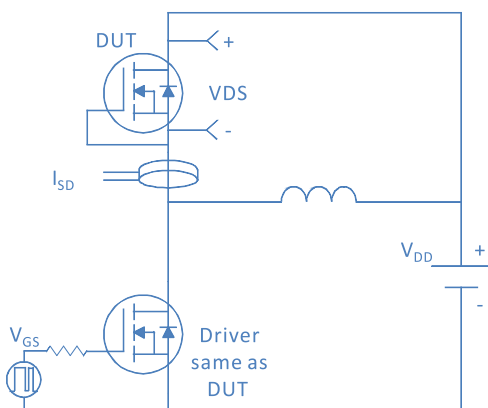



TO-220, 3 leads

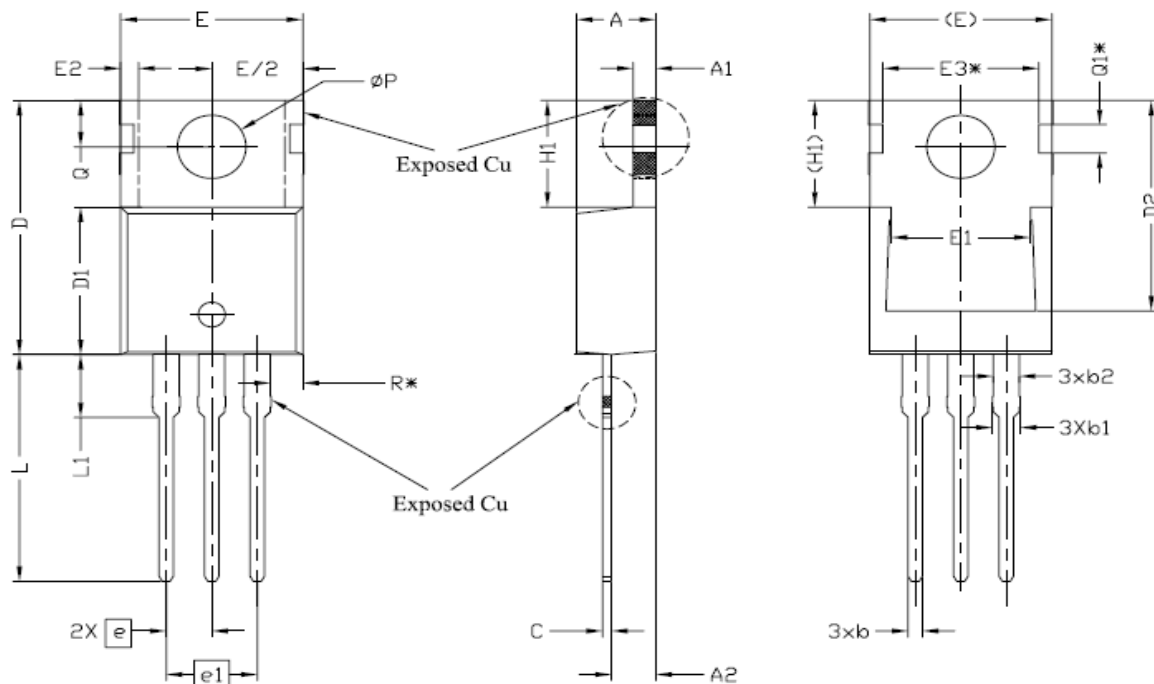

SYMBOL	DIMENSIONS			NOTES
	MIN.	NOM.	MAX.	
A	4,24	4,44	4,64	
A1	1,15	1,27	1,40	
A2	2,30	2,48	2,70	
b	0,70	0,80	0,90	
b1	1,20	1,55	1,75	
b2	1,20	1,45	1,70	
c	0,40	0,50	0,60	
D	14,70	15,37	16,00	4
D1	8,82	8,92	9,02	
D2	12,63	12,73	12,83	5
E	9,96	10,16	10,36	4,5
E1	6,86	7,77	8,89	5
E2	-	-	0,76	6
E3*	8,70REF.			
e	2,54BSC			
e1	5,08BSC			
H1	6,30	6,45	6,60	5,6
L	13,47	13,72	13,97	
L1	3,60	3,80	4,00	
∅P	3,75	3,84	3,93	
Q	2,60	2,80	3,00	
Q1*	1,73REF.			
R*	1,82REF.			



Outlines TO-263 Package

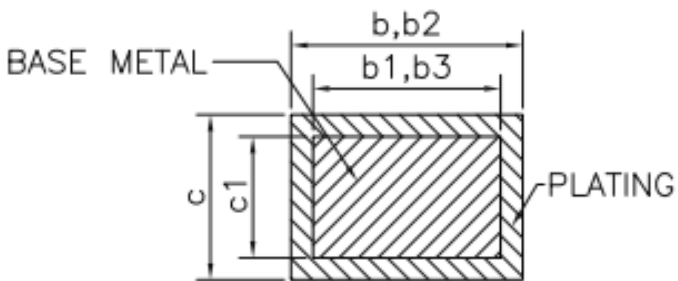
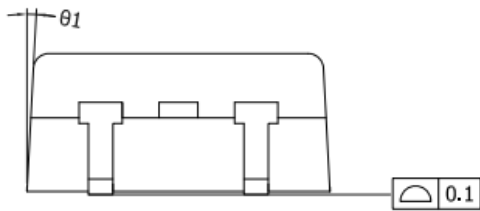
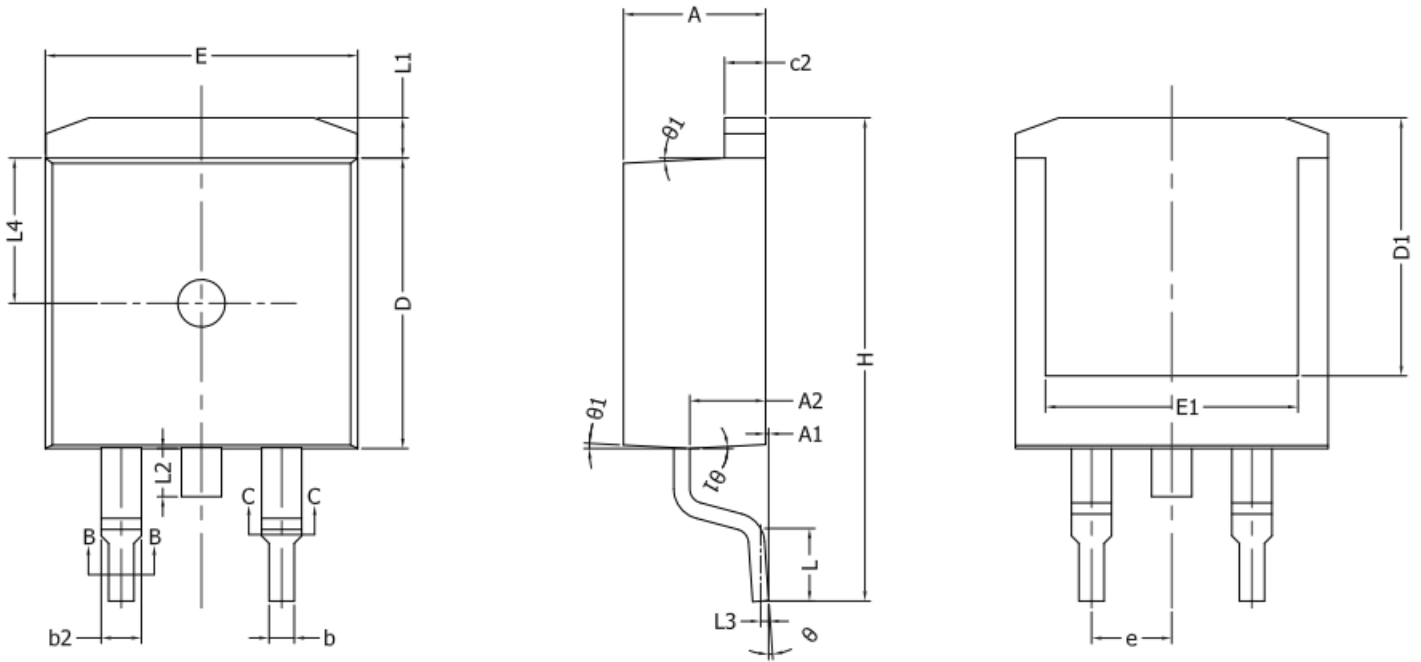

SECTION B-B&C-C

SYMBOL	MIN	NOM	MAX
A	4.4	4.5	4.6
A1	0	0.1	0.25
A2	2.2	2.4	2.6
b	0.76	--	0.89
b1	0.75	0.8	0.85
b2	1.23	--	1.37
b3	1.22	1.27	1.32
c	0.47	--	0.6
c1	0.46	0.51	0.56
c2	1.25	1.3	1.35
D	9.1	9.2	9.3
D1	8	--	--
E	9.8	9.9	10
E1	7.8	--	--
e	2.54 BSC		
H	14.9	15.3	15.7
L	2	2.3	2.6
L1	1.17	1.27	1.4
L2	--	--	1.75
L3	0.25 BSC		
L4	4.60 REF		
theta	0°	--	8°
theta1	1°	3°	5°



Outlines TO-247 Package

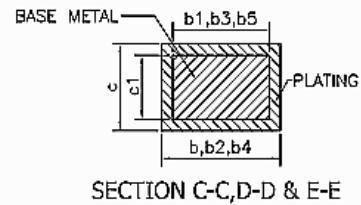
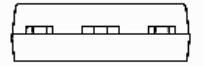
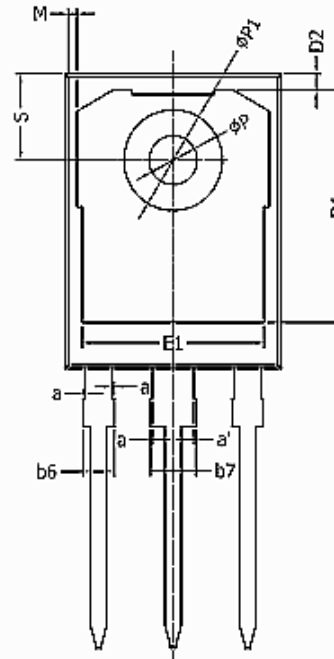
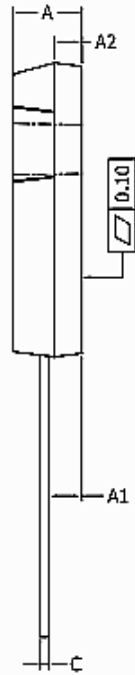
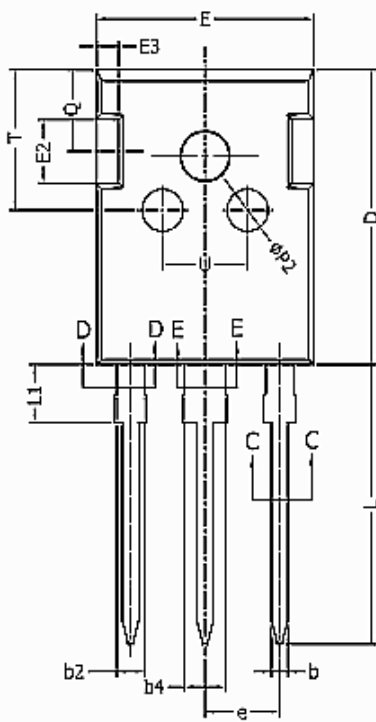

SYMBOL	MIN	NOM	MAX
A	4.9	5	5.1
A1	2.31	2.41	2.51
A2	1.9	2	2.1
a	0	---	0.15
a'	0	---	0.15
b	1.16	---	1.26
b1	1.15	1.2	1.22
b2	1.96	---	2.06
b3	1.95	2	2.02
b4	2.96	---	3.06
b5	2.96	3	3.02
b6	---	---	2.25
b7	---	---	3.25
c	0.59	---	0.66
c1	0.58	0.6	0.62
D	20.9	21	21.1
D1	16.25	16.55	16.85

SYMBOL	MIN	NOM	MAX
D2	1.05	1.17	1.35
E	15.7	15.8	15.9
E1	13.1	13.3	13.5
E2	4.4	4.5	4.6
E3	2.4	2.5	2.6
e	5.436 BSC		
L	19.8	19.92	20.1
L1	---	---	4.3
M	0.35	---	0.95
P	3.4	3.5	3.6
P1	7	---	7.4
P2	2.4	2.5	2.6
Q	5.6	---	6
S	6.05	6.15	6.25
T	9.8	---	10.2
U	6	---	6.4



Disclaimer

Brunei has made reasonable commercial efforts to ensure that the information given in this datasheet is correct. However, it must clearly be understood that such information is for guidance only and does not constitute any representation or form part of any offer or contract.

For documents and material available from this datasheet, Brunei does not warrant or assume any legal liability or responsibility for the accuracy, completeness, or usefulness of any information, product, technology or process disclosed hereunder.

Brunei reserves the rights to at its own discretion to make any changes or improvements to this datasheet. Unless said datasheet is incorporated into the formal contract, any customer should not rely on the information as any specification or product parameters duly committed by Brunei Customers are hereby advised to verify that the information contained herein is current and complete before the entering of any contract or acknowledgement of any purchase order. Accordingly, all products specified hereunder shall be sold subject to Brunei's terms and conditions supplied at the time of order acknowledgement. Except where agreed upon by contractual agreement, testing of all parameters of each product is not necessarily performed.

Brunei does not warrant or convey any license either expressed or implied under its patent rights, nor the rights of others. Reproduction of information contained herein shall be only permissible if such reproduction is without any modification or alteration. Reproduction of this information with any alteration is an unfair and deceptive business practice. Brunei is not responsible or liable for such altered documentation.

Resale of Brunei's products with statements different from or beyond the parameters stated by Brunei for that product or service voids all express or implied warranties for the associated Brunei's product or service and is unfair and deceptive business practice. Brunei is not responsible or liable for any such statements.

Brunei's products are not authorized for use as critical components in life support devices or systems without the express written approval of Brunei. As used herein:

1. Life support devices or systems are devices or systems which, (a) are intended for surgical implant into the body, or (b) support or sustain life, and whose failure to perform, when properly used in accordance with instructions for use provided in the labeling, can be reasonably expected to result in a significant injury to the user.
2. A critical component is any component of a life support device or system whose failure to perform can be reasonably expected to cause the failure of the life support device or system, or to affect its safety or effectiveness.