



Features

- Low On Resistance
- Low Gate Charge
- Fast Switching Characteristic

BV_{DSS}	-200V
$I_D @ V_{GS} = -10V, T_C = 25^\circ C$	-19A
$I_D @ V_{GS} = -10V, T_A = 25^\circ C$	-3A
$R_{DS(ON) \text{ typ.}} @ V_{GS} = -10V, I_D = -3A$	125m Ω

Equivalent Circuit

WLB15P20

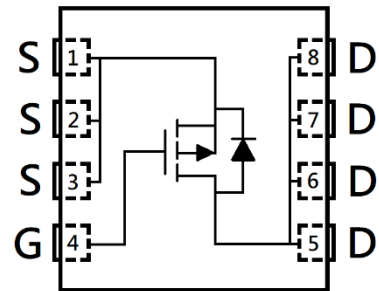

G : Gate S : Source D : Drain

SOP8 Pin Configuration

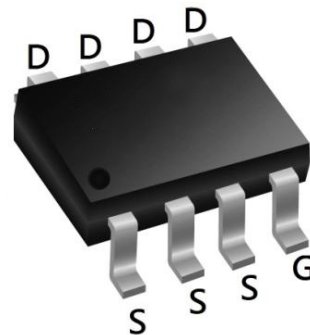

**Absolute Maximum Ratings (T_A=25°C)**

Parameter	Symbol	Limits	Unit	
Drain-Source Voltage	V _{DS}	-200	V	
Gate-Source Voltage	V _{GS}	±20		
Continuous Drain Current @ V _{GS} =-10V, T _C =25°C	I _D	-19	A	
Continuous Drain Current @ V _{GS} =-10V, T _C =100°C		-12		
Continuous Drain Current @ V _{GS} =-10V, T _A =25°C		-3		
Continuous Drain Current @ V _{GS} =-10V, T _A =70°C		-2.4		
Pulsed Drain Current	I _{DM}	-76		
Continuous Body Diode Forward Current @ T _C =25°C	I _S	-19		
Avalanche Current @ L=0.1mH	I _{AS}	-35		
Avalanche Energy @ L=0.5mH	E _{AS}	100	mJ	
Total Power Dissipation	P _D	T _C =25°C	125	W
		T _C =100°C	50	
		T _A =25°C	3.2	
		T _A =70°C	2	
Operating Junction and Storage Temperature Range	T _J , T _{stg}	-55~+150	°C	

Thermal Data

Parameter	Symbol	Steady State	Unit
Thermal Resistance, Junction-to-case	R _{θJC}	1	°C/W
Thermal Resistance, Junction-to-ambient	R _{θJA}	40	

Note:

- *a. The power dissipation P_D is based on T_{J(MAX)}=150°C, using junction-to-case thermal resistance, and is more useful in setting the upper dissipation limit for cases where additional heatsinking is used.
- *b. The value of R_{θJA} is measured with the device mounted on 1 in² FR-4 board with 2 oz. copper, in a still air environment with T_A=25°C. The power dissipation P_D is based on R_{θJA} and the maximum allowed junction temperature of 150°C. The value in any given application depends on the user's specific board design.
- *c. Repetitive rating, pulse width limited by junction temperature T_{J(MAX)}=150°C. Ratings are based on low frequency and low duty cycles to keep initial T_J=25°C.



Electrical Characteristics (T_A=25°C, unless otherwise specified)

Symbol	Min.	Typ.	Max.	Unit	Test Conditions
Static					
BV _{DSS}	-200	-	-	V	V _{GS} =0V, I _D =-250μA
V _{GS(th)}	-2	-	-4		V _{DS} =V _{GS} , I _D =-250μA
G _{FS}	-	11	-	S	V _{DS} =-15V, I _D =-3A
I _{GSS}	-	-	±100	nA	V _{GS} =±20V, V _{DS} =0V
I _{DSS}	-	-	-1	μA	V _{DS} =-160V, V _{GS} =0V
R _{DS(ON)}	-	125	165	mΩ	V _{GS} =-10V, I _D =-3A
Dynamic					
C _{iSS}	-	2484	-	pF	V _{DS} =-100V, V _{GS} =0V, f=1MHz
C _{oSS}	-	127	-		
C _{rSS}	-	71	-		
R _g	-	3.6	-	Ω	f=1MHz
Q _g *1, 2	-	48	-	nC	V _{DS} =-75V, I _D =-3A, V _{GS} =-10V
Q _{gs} *1, 2	-	11	-		
Q _{gd} *1, 2	-	14	-		
t _{d(ON)} *1, 2	-	25	-	ns	V _{DS} =-75V, I _D =-3A, V _{GS} =-10V, R _{GS} =6Ω
t _r *1, 2	-	22	-		
t _{d(OFF)} *1, 2	-	68	-		
t _f *1, 2	-	37	-		
Source-Drain Diode					
V _{SD} *1	-	-0.8	-1.2	V	I _S =-3A, V _{GS} =0V
t _{rr}	-	52	-	ns	I _F =-3A, dI _F /dt=100A/μs
Q _{rr}	-	126	-	nC	

Note:

*1. Pulse Test : Pulse Width ≤300μs, Duty Cycle≤2%

*2. Independent of operating temperature



Typical Characteristics

Typical Output Characteristics

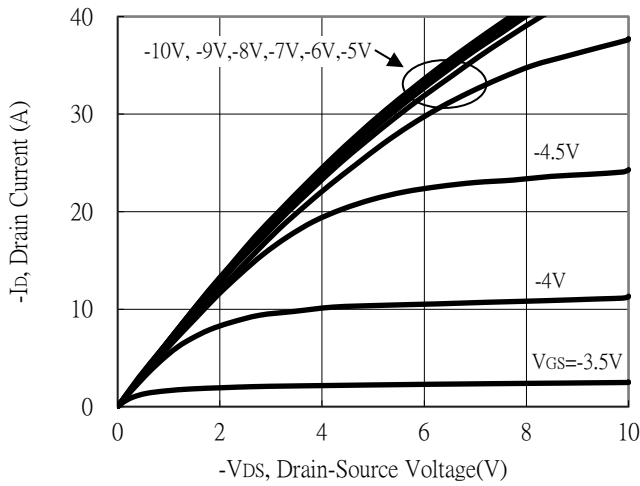

Breakdown Voltage vs Ambient Temperature

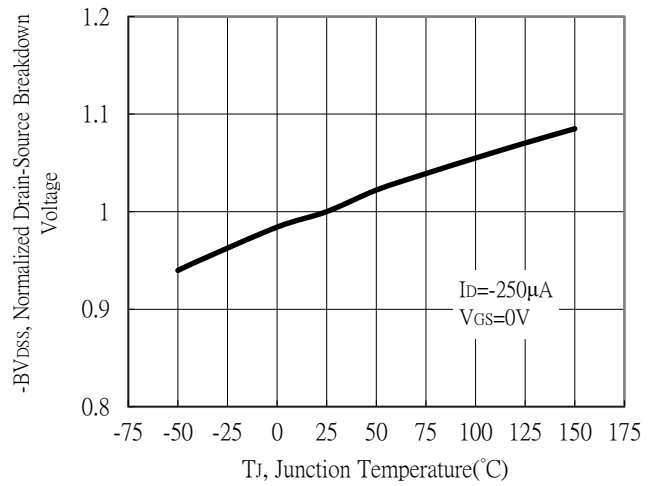

Static Drain-Source On-State resistance vs Drain Current

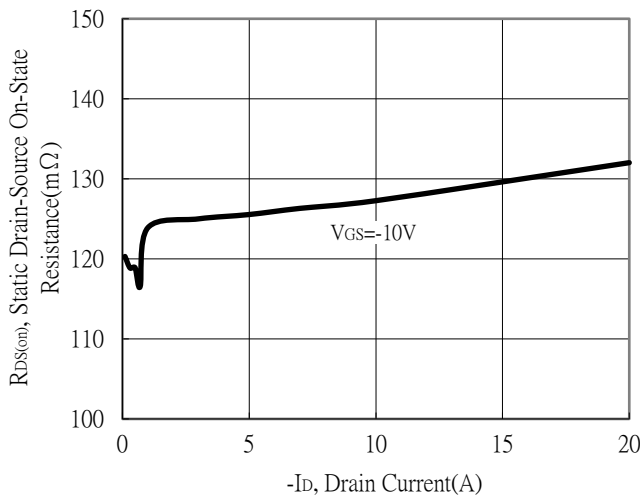

Body Diode Current vs Source-Drain Voltage

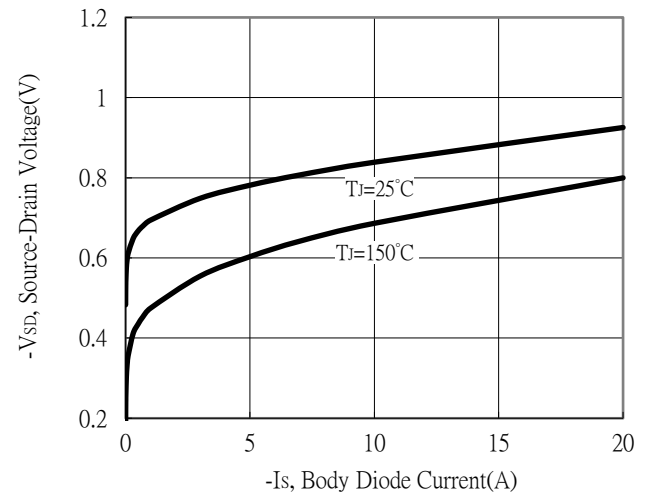

Static Drain-Source On-State Resistance vs Gate-Source Voltage

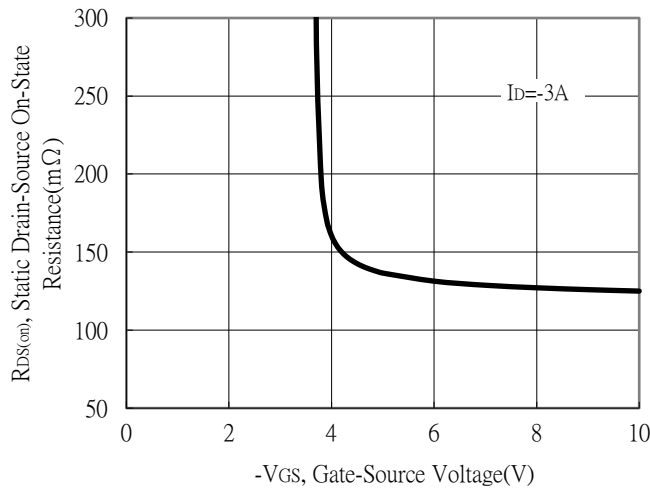

Drain-Source On-State Resistance vs Junction Temperature

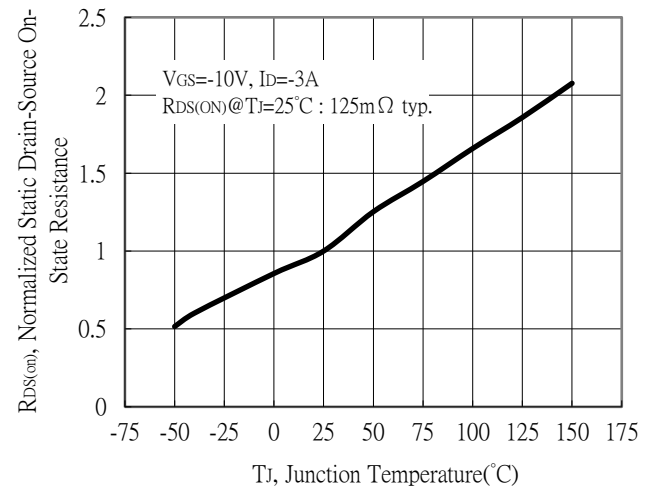



Typical Characteristics (Cont.)

Capacitance vs Drain-to-Source Voltage

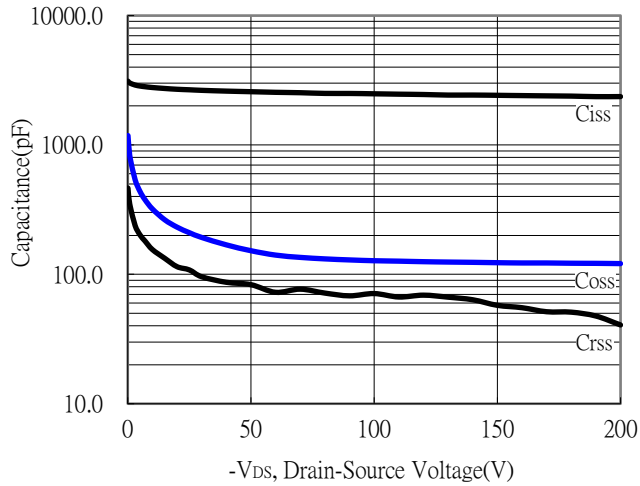

Threshold Voltage vs Junction Temperature

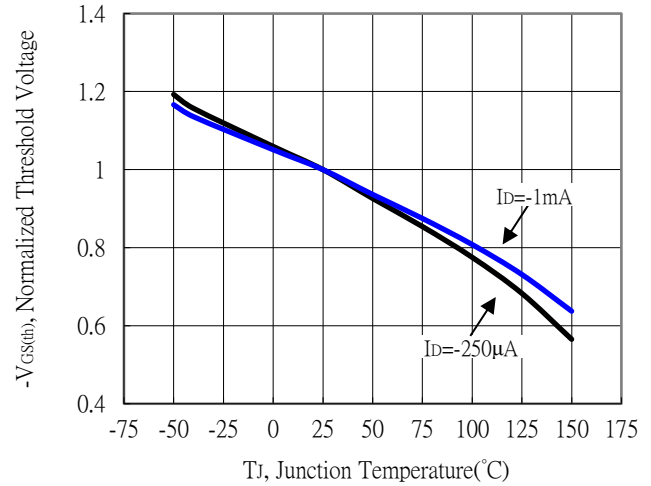

Forward Transfer Admittance vs Drain Current

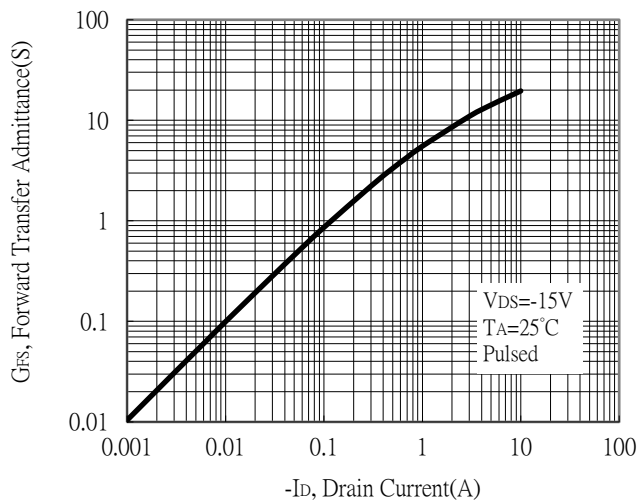

Gate Charge Characteristics

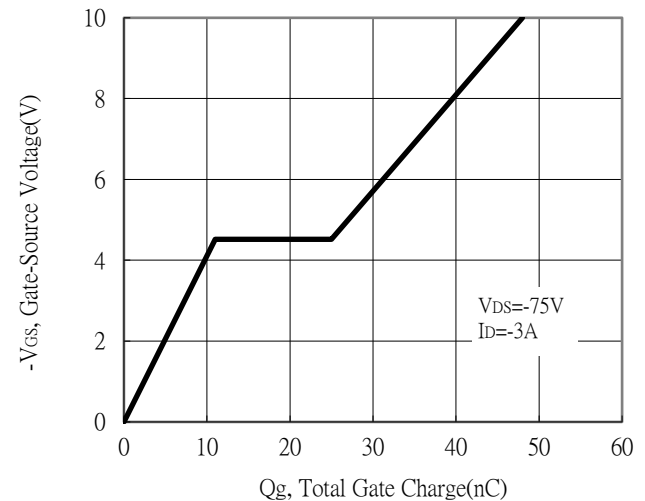

Maximum Safe Operating Area

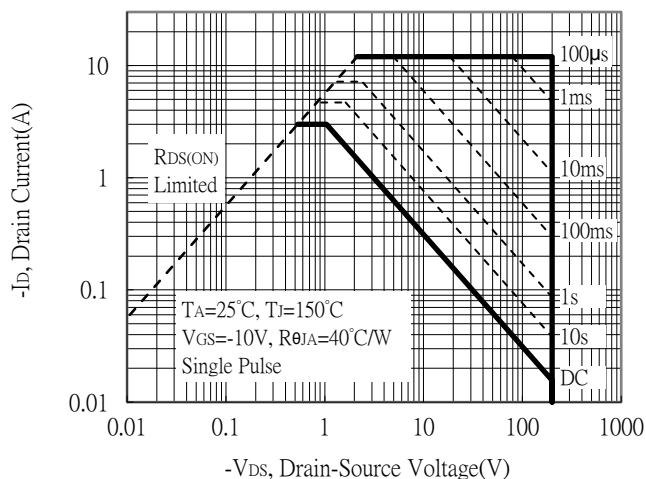

Maximum Drain Current vs Junction Temperature

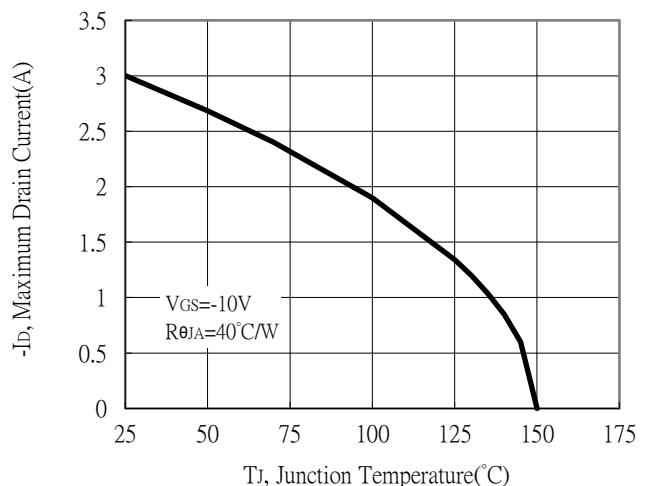



Typical Characteristics (Cont.)

Single Pulse Power Rating, Junction to Ambient

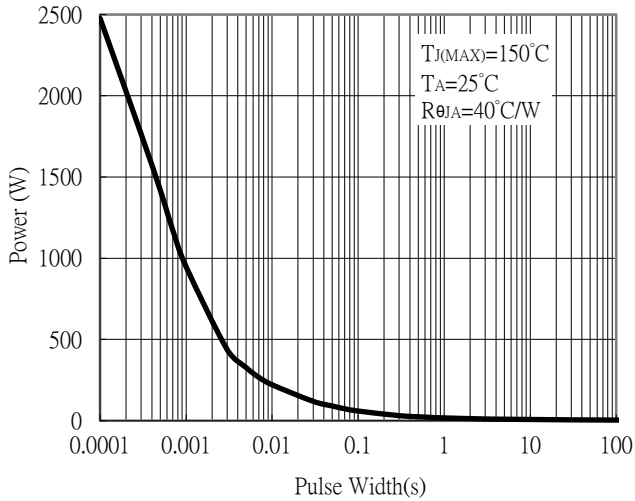

Transient Thermal Response Curves

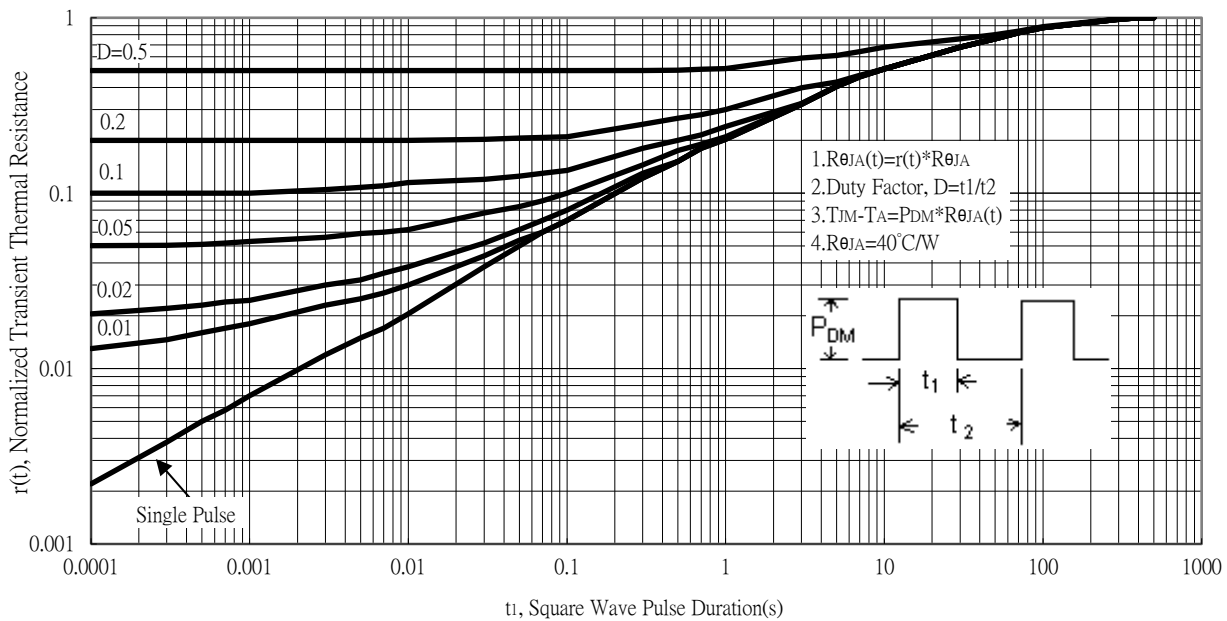

Recommended Soldering Footprint

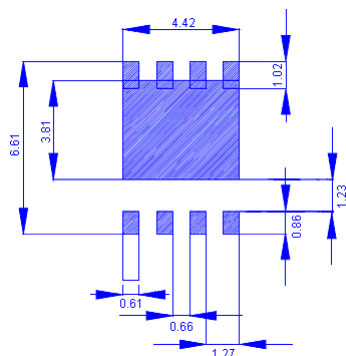

unit : mm(H forming)

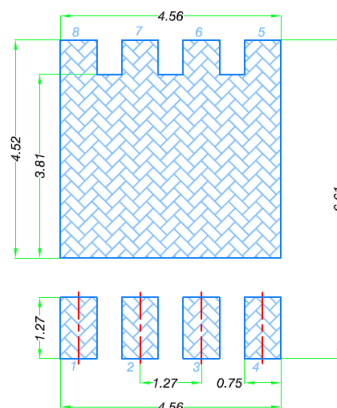

unit : mm(G forming)



Reel Dimension

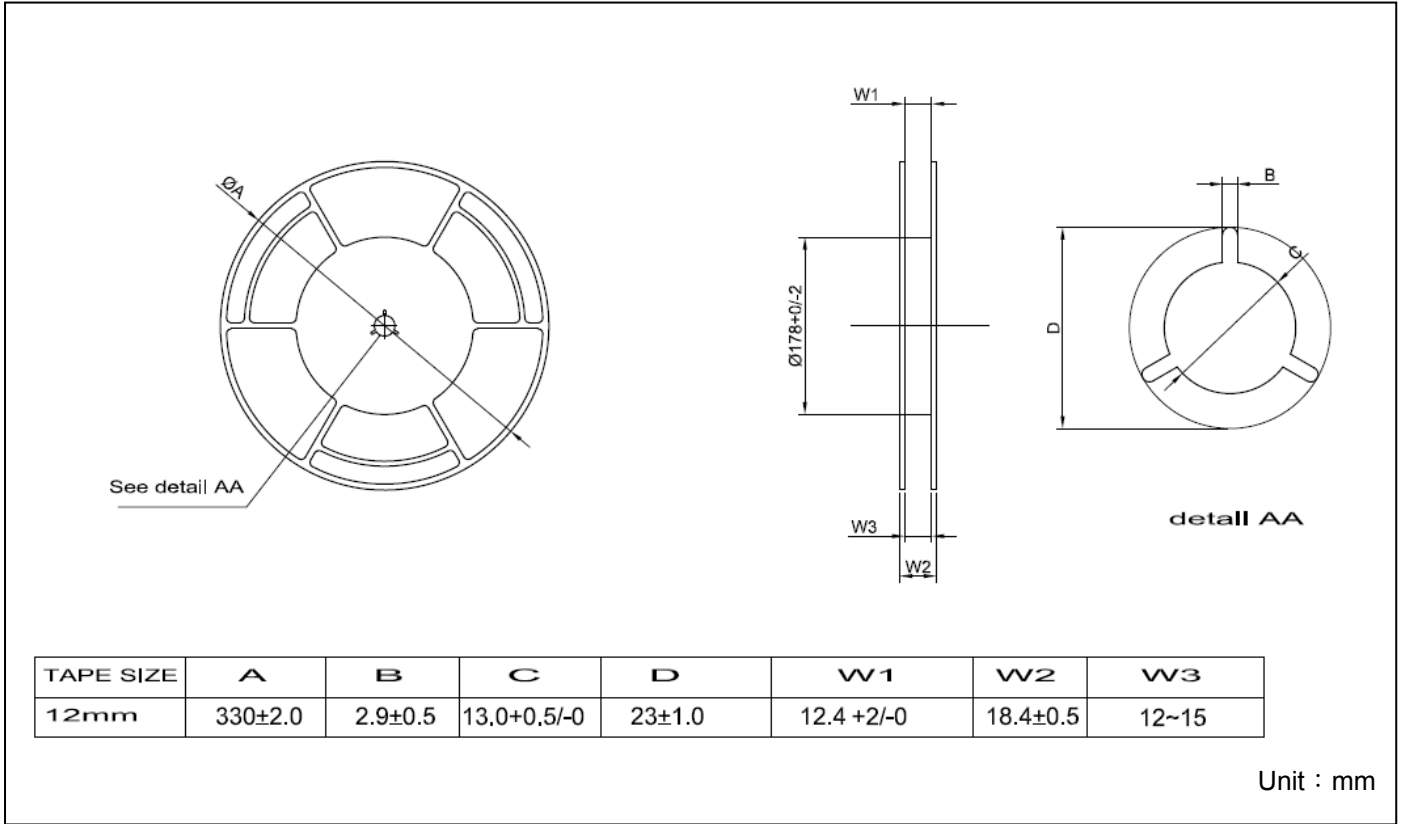

Carrier Tape Dimension

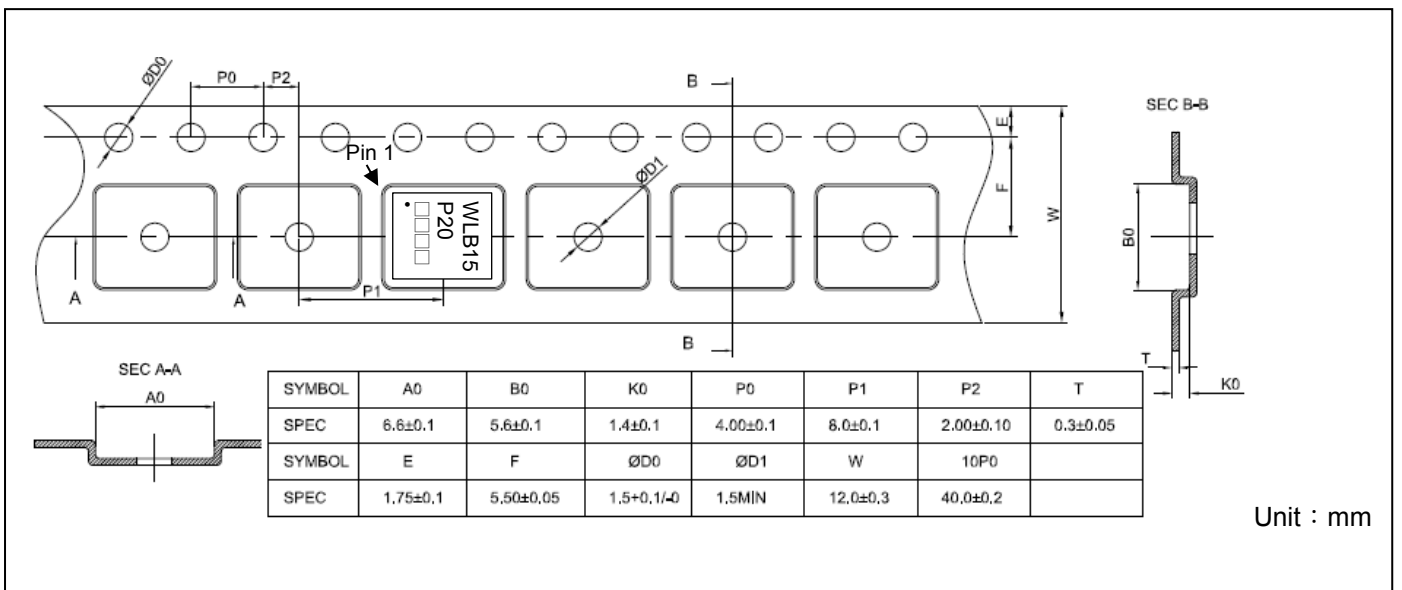



Recommended wave soldering condition

Product	Peak Temperature	Soldering Time
Pb-free devices	260 +0/-5 °C	5 +1/-1 seconds

Recommended temperature profile for IR reflow

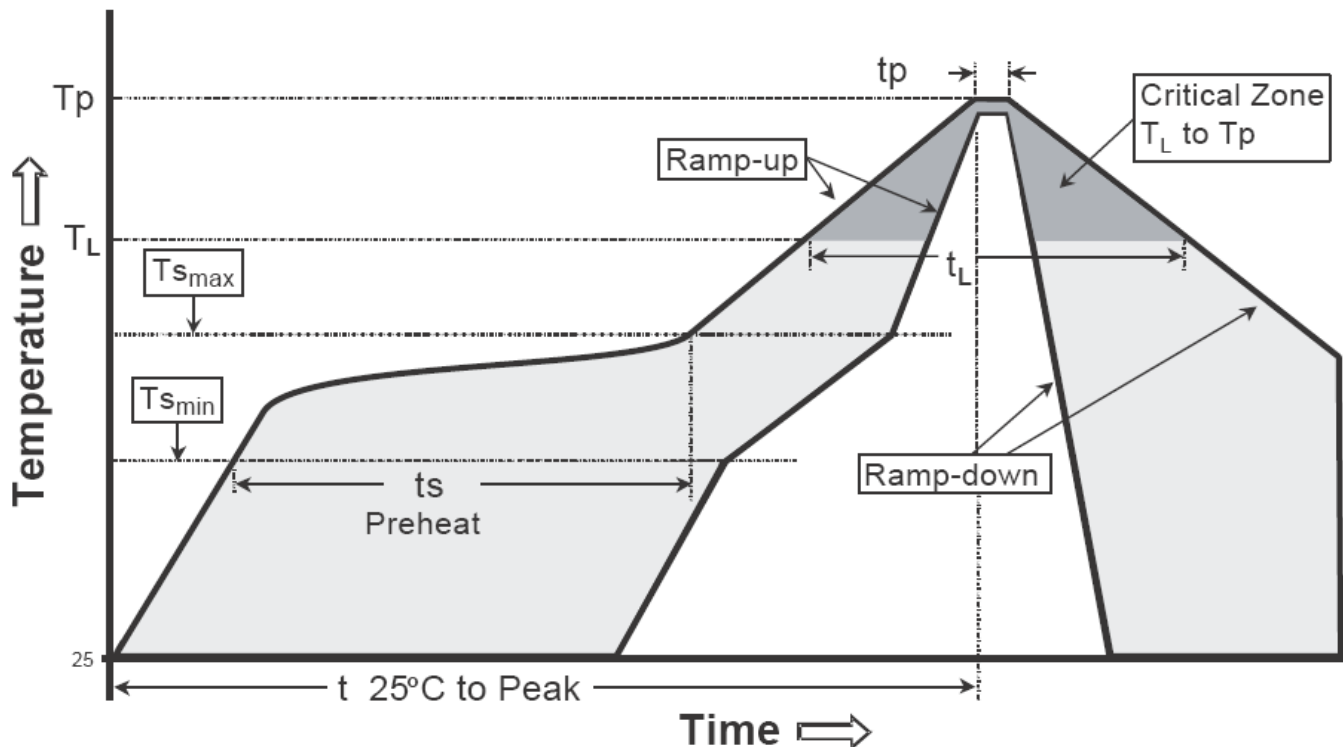

Profile feature	Sn-Pb eutectic Assembly	Pb-free Assembly
Average ramp-up rate (Tsmax to Tp)	3°C/second max.	3°C/second max.
Preheat		
-Temperature Min(Ts min)	100°C	150°C
-Temperature Max(Ts max)	150°C	200°C
-Time(ts min to ts max)	60-120 seconds	60-180 seconds
Time maintained above:		
-Temperature (Tl)	183°C	217°C
- Time (tl)	60-150 seconds	60-150 seconds
Peak Temperature(Tp)	240 +0/-5 °C	260 +0/-5 °C
Time within 5°C of actual peak temperature(tp)	10-30 seconds	20-40 seconds
Ramp down rate	6°C/second max.	6°C/second max.
Time 25 °C to peak temperature	6 minutes max.	8 minutes max.

Note : All temperatures refer to topside of the package, measured on the package body surface.



DFN5x6 Dimension (H forming)

Marking :

Device Name → **WLB15 P20**

Date Code → □ □ □ □ H

Assembly site code :
H : site 1
G : site 2

8-Lead DFN5×6 Plastic Package
CYS Package Code : H8

Date Code(counting from left to right) :
1st code: year code, the last digit of Christian year
2nd code : month code, Jan→A, Feb→B, Mar→C,
Apr→D, May→E, Jun→F, Jul→G, Aug→H,
Sep→J, Oct→K, Nov→L, Dec→M
3rd and 4th codes : production serial number, 01~99

DIM	Millimeters		Inches		DIM	Millimeters		Inches	
	Min.	Max.	Min.	Max.		Min.	Max.	Min.	Max.
A	1.000	1.200	0.0394	0.0472	E2	5.660	6.060	0.2228	0.2386
b	0.300	0.500	0.0118	0.0197	E4	3.520	3.920	0.1386	0.1543
C	0.154	0.354	0.0061	0.0139	H	0.400	0.600	0.0157	0.0236
D1	5.000	5.400	0.1969	0.2126	L	0.300	0.700	0.0118	0.0276
D2	3.800	4.250	0.1496	0.1673	L1	0.000	0.120	0.0000	0.0047
e	1.170	1.370	0.0461	0.0539	K	1.34 REF		0.0527 REF	
E1	5.950	6.350	0.2343	0.2500					

Notes: 1.Controlling dimension: millimeters.
2.Maximum lead thickness includes lead finish thickness, and minimum lead thickness is the minimum thickness of base material.
3.If there is any question with packing specification or packing method, please contact your local CYStek sales office.

Material:

- Lead: Pure tin plated.
- Mold Compound: Epoxy resin family, flammability solid burning class: UL94V-0.

Important Notice:

- All rights are reserved. Reproduction in whole or in part is prohibited without the prior written approval of CYStek.
- CYStek reserves the right to make changes to its products without notice.
- CYStek **semiconductor products are not warranted to be suitable for use in Life-Support Applications, or systems.**
- CYStek assumes no liability for any consequence of customer product design, infringement of patents, or application assistance.



DFN5x6 Dimension (G forming)

Marking:

Device Code → WLB15
P20

Date Code → □□□□ G

Assembly site code:
H : site 1
G : site 2

Date Code (counting from left to right):
1st code: year code, the last digit of Christian year
2nd code: month code, Jan→A, Feb→B, Mar→C, Apr→D, May→E, Jun→F, Jul→G, Aug→H, Sep→J, Oct→K, Nov→L, Dec→M
3rd and 4th codes: production serial number, 01~99

8-Lead DFN5x6 Plastic Package
CYS Package Code : H8

DIM	Millimeters		Inches		DIM	Millimeters		Inches	
	Min.	Max.	Min.	Max.		Min.	Max.	Min.	Max.
A	1.00	1.20	0.039	0.047	E2	3.52	3.92	0.138	0.154
A1	0.00	0.05	0.000	0.001	e	1.27	BSC	0.050	BSC
b	0.33	0.50	0.012	0.019	H	0.40	0.60	0.015	0.023
c	0.20	0.30	0.007	0.011	K	1.10	-	0.043	-
D1	5.00	5.40	0.196	0.212	L	0.50	0.70	0.019	0.027
D2	3.80	4.25	0.149	0.167	L1	0.08	0.22	0.003	0.008
E	6.00	6.30	0.236	0.248	α	0°	12°	0°	12°
E1	5.76	5.96	0.226	0.234					

Notes: 1. Controlling dimension: millimeters.
2. Maximum lead thickness includes lead finish thickness, and minimum lead thickness is the minimum thickness of base material.
3. If there is any question with packing specification or packing method, please contact your local CYStek sales office.

Material:

- Lead: Pure tin plated.
- Mold Compound: Epoxy resin family, flammability solid burning class: UL94V-0.

Important Notice:

- All rights are reserved. Reproduction in whole or in part is prohibited without the prior written approval of CYStek.
- CYStek reserves the right to make changes to its products without notice.
- CYStek **semiconductor products are not warranted to be suitable for use in Life-Support Applications, or systems.**
- CYStek assumes no liability for any consequence of customer product design, infringement of patents, or application assistance.



Disclaimer

Brunei has made reasonable commercial efforts to ensure that the information given in this datasheet is correct. However, it must clearly be understood that such information is for guidance only and does not constitute any representation or form part of any offer or contract.

For documents and material available from this datasheet, Brunei does not warrant or assume any legal liability or responsibility for the accuracy, completeness, or usefulness of any information, product, technology or process disclosed hereunder.

Brunei reserves the rights to at its own discretion to make any changes or improvements to this datasheet. Unless said datasheet is incorporated into the formal contract, any customer should not rely on the information as any specification or product parameters duly committed by Brunei Customers are hereby advised to verify that the information contained herein is current and complete before the entering of any contract or acknowledgement of any purchase order. Accordingly, all products specified hereunder shall be sold subject to Brunei's terms and conditions supplied at the time of order acknowledgement. Except where agreed upon by contractual agreement, testing of all parameters of each product is not necessarily performed.

Brunei does not warrant or convey any license either expressed or implied under its patent rights, nor the rights of others. Reproduction of information contained herein shall be only permissible if such reproduction is without any modification or alteration. Reproduction of this information with any alteration is an unfair and deceptive business practice. Brunei is not responsible or liable for such altered documentation.

Resale of Brunei's products with statements different from or beyond the parameters stated by Brunei for that product or service voids all express or implied warranties for the associated Brunei's product or service and is unfair and deceptive business practice. Brunei is not responsible or liable for any such statements.

Brunei's products are not authorized for use as critical components in life support devices or systems without the express written approval of Brunei. As used herein:

1. Life support devices or systems are devices or systems which, (a) are intended for surgical implant into the body, or (b) support or sustain life, and whose failure to perform, when properly used in accordance with instructions for use provided in the labeling, can be reasonably expected to result in a significant injury to the user.
2. A critical component is any component of a life support device or system whose failure to perform can be reasonably expected to cause the failure of the life support device or system, or to affect its safety or effectiveness.