

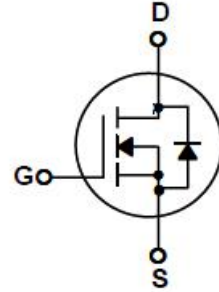

### General Description

This Power MOSFET is produced by WENLAI using its own advanced planar stripe DMOS technology. This advanced technology has been especially tailored to minimize on-state resistance, provide superior switching performance, and withstand high energy pulse in the avalanche and commutation mode. These devices are well suited for high efficiency switched mode power supplies, active power factor correction based on half bridge topology.



TO-220F Package

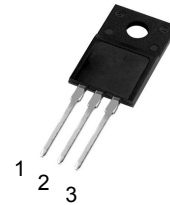

1. Gate 2. Drain 3. Source

### Features

- 18A, 500V, RDS(on) = 225mΩ @VGS = 10 V
- Low gate charge ( typical 38nC)
- Low Crss ( typical 6.6pF)
- Fast switching
- 100% avalanche tested
- Improved dv/dt capability

Symbol	Parameter	Value	Units
V <sub>DSS</sub>	Drain-Source Voltage	500	V
I <sub>D</sub>	Drain Current - Continuous (TC= 25°C) - Continuous (TC= 100°C)	18	A
		11.7*	A
I <sub>DM</sub>	Drain Current - Pulsed (Note 1)	72*	A
V <sub>GSS</sub>	Gate-Source Voltage	± 30	V
E <sub>AS</sub>	Single Pulsed Avalanche Energy (Note 2)	662	mJ
I <sub>AR</sub>	Avalanche Current (Note 1)	18	A
E <sub>AR</sub>	Repetitive Avalanche Energy (Note 1)	70	mJ
dv/dt	Peak Diode Recovery dv/dt (Note 3)	5	V/ns
P <sub>D</sub>	Power Dissipation (TC = 25°C) - Derate above 25°C	34	W
		0.27	W/°C
T <sub>J</sub> , T <sub>stg</sub>	Operating and Storage Temperature Range	-55 to +150	°C
T <sub>L</sub>	Maximum lead temperature for soldering purposes, 1/8" from case for 5 seconds	300	°C

\* Drain current limited by maximum junction temperature

### Thermal Characteristics

Symbol	Parameter	Value	Units
R <sub>θJC</sub>	Thermal Resistance, Junction-to-Case	3.68	°C/W
R <sub>θJS</sub>	Thermal Resistance, Case-to-Sink Typ.	--	°C/W
R <sub>θJA</sub>	Thermal Resistance, Junction-to-Ambient	44.0	°C/W



### Electrical Characteristics TC = 25°C unless otherwise noted

Symbol	Parameter	Test Conditions	Min	Typ	Max	Units
<b>Off Characteristics</b>						
$BV_{DSS}$	Drain-Source Breakdown Voltage	$V_{GS} = 0\text{ V}, I_D = 250\ \mu\text{A}$	500			V
$\frac{\Delta BV_{DSS}}{\Delta T_J}$	Breakdown Voltage Temperature Coefficient	$I_D = 250\ \mu\text{A}$ , Referenced to 25°C		0.51		V/°C
$I_{DSS}$	Zero Gate Voltage Drain Current	$V_{DS} = 500\text{ V}, V_{GS} = 0\text{ V}$			1	$\mu\text{A}$
		$V_{DS} = 400\text{ V}, TC = 125^\circ\text{C}$			10	$\mu\text{A}$
$I_{GSSF}$	Gate-Body Leakage Current, Forward	$V_{GS} = 30\text{ V}, V_{DS} = 0\text{ V}$			100	nA
$I_{GSSR}$	Gate-Body Leakage Current, Reverse	$V_{GS} = -30\text{ V}, V_{DS} = 0\text{ V}$			-100	nA
<b>On Characteristics</b>						
$V_{GS(TH)}$	Gate Threshold Voltage	$V_{DS}=V_{GS}, I_D=250\ \mu\text{A}$	3.0		5.0	V
$R_{DS(On)}$	Drain-Source On-state Resistance	$V_{GS}=10\text{ V}, I_D=9\text{ A}, T_J = 25^\circ\text{C}$		225	330	m $\Omega$
$g_{FS}$	Forward Transconductance	$V_{DS} = 40\text{ V}, I_D = 9\text{ A}$ (Note 4)		19		S
<b>Dynamic Characteristics</b>						
$C_{iss}$	Input Capacitance	$V_{DS} = 25\text{ V}, V_{GS} = 0\text{ V}, f = 1.0\text{ MHz}$		2219		pF
$C_{oss}$	Output Capacitance			321		pF
$C_{rss}$	Reverse Transfer Capacitance			6.6		pF
<b>Switching Characteristics</b>						
$t_{d(on)}$	Turn On Delay Time	$V_{DD} = 250\text{ V}, I_D = 18\text{ A}, R_G = 25\ \Omega$ (Note 4, 5)		34		ns
$t_r$	Rising Time			46		ns
$t_{d(off)}$	Turn Off Delay Time			89		ns
$t_f$	Fall Time			41		ns
$Q_g$	Total Gate Charge			38		nC
$Q_{gs}$	Gate-Source Charge	$V_{DS} = 250\text{ V}, I_D = 18\text{ A}, V_{GS} = 10\text{ V}$ (Note 4, 5)		12		nC
$Q_{gd}$	Gate-Drain Charge			13		nC
<b>Drain-Source Diode Characteristics and Maximum Ratings</b>						
$I_S$	Maximum Continuous Drain-Source Diode Forward Current				18	A
$I_{SM}$	Maximum Pulsed Drain-Source Diode Forward Current				72	A
$V_{SD}$	Diode Forward Voltage	$V_{GS} = 0\text{ V}, I_S = 18\text{ A}$			1.4	V
$t_{rr}$	Reverse Recovery Time	$V_{GS} = 0\text{ V}, I_S = 18\text{ A}, di_F / dt = 100\text{ A}/\mu\text{s}$ (Note 4)		337		ns
$Q_{rr}$	Reverse Recovery Charge			4.3		$\mu\text{C}$

**Notes:**

1. Repetitive Rating : Pulse width limited by maximum junction temperature
2.  $L = 4.1\text{ mH}, I_{AS} = 18\text{ A}, V_{DD} = 50\text{ V}, R_G = 25\ \Omega$ , Starting  $T_J = 25^\circ\text{C}$
3.  $I_{SD} \leq 20\text{ A}, di/dt \leq 200\text{ A}/\mu\text{s}, V_{DD} \leq BV_{DSS}$ , Starting  $T_J = 25^\circ\text{C}$
4. Pulse Test : Pulse width  $\leq 300\ \mu\text{s}$ , Duty cycle  $\leq 2\%$
5. Essentially independent of operating temperature



### Typical Characteristics

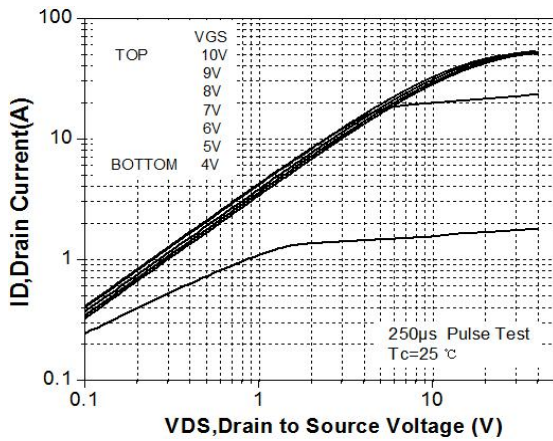

Figure 1. On-Region Characteristics

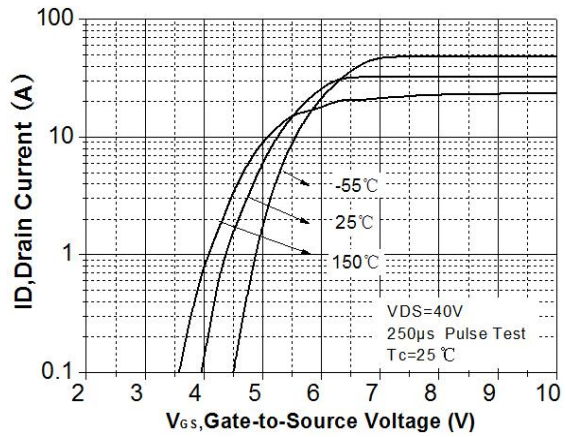

Figure 2. Transfer Characteristics

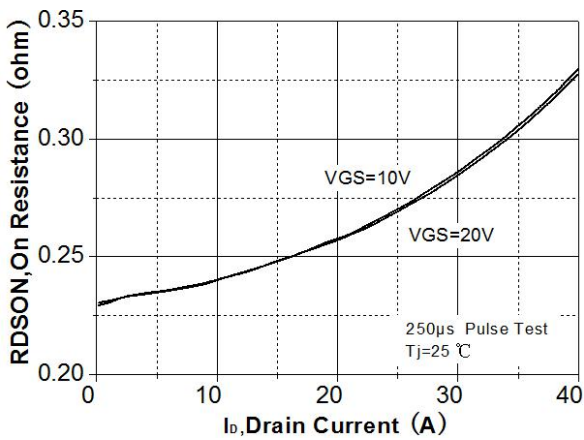

Figure 3. On-Resistance Variation vs Drain Current and Gate Voltage

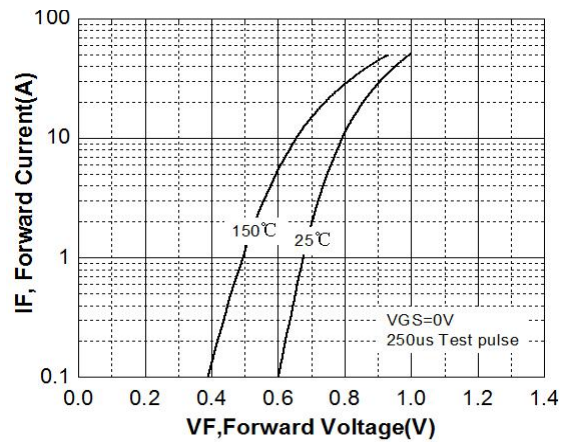

Figure 4. Body Diode Forward Voltage Variation with Source Current and Temperature

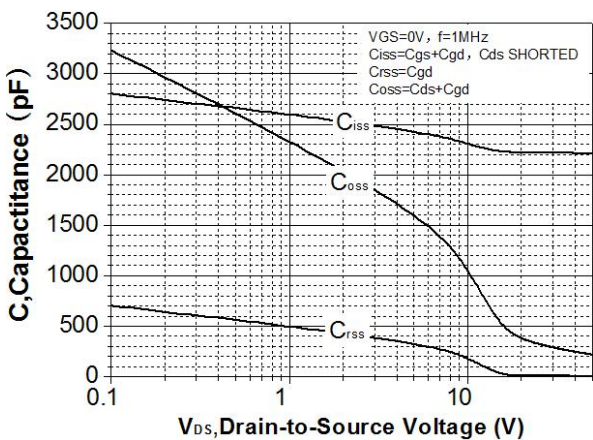

Figure 5. Capacitance Characteristics

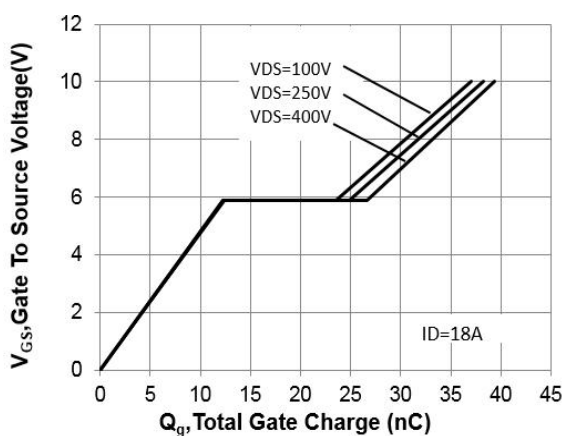

Figure 6. Gate Charge Characteristics



### Typical Characteristics (Continued)

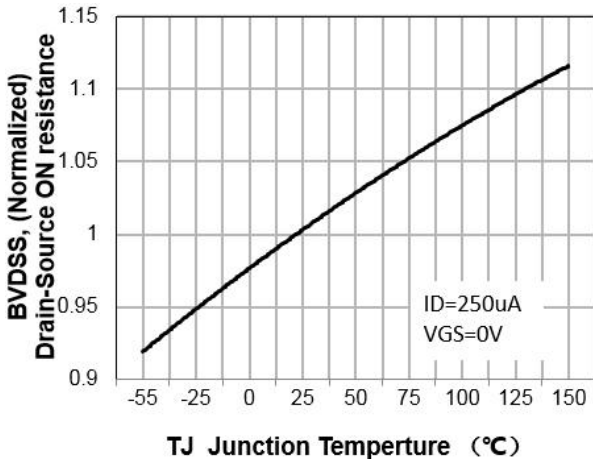

Figure 7. Breakdown Voltage Variation vs Temperature

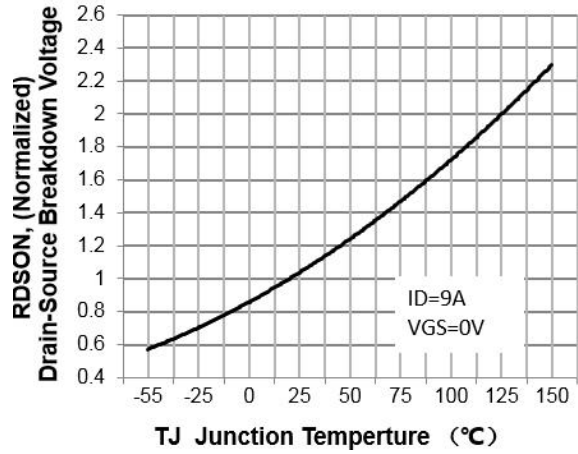

Figure 8. On-Resistance Variation vs Temperature

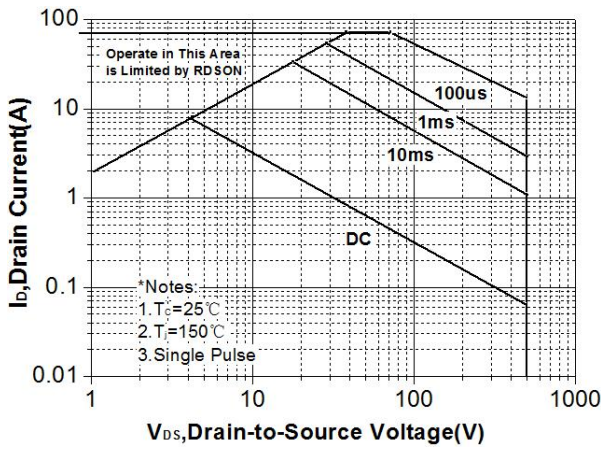

Figure 9. Maximum Safe Operating Area

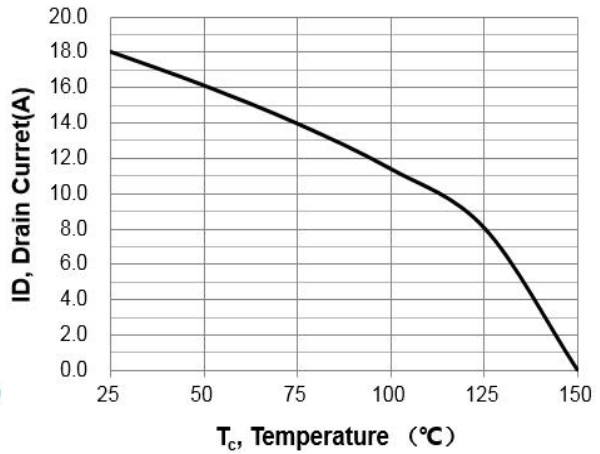

Figure 10. Maximum Drain Current vs Case Temperature

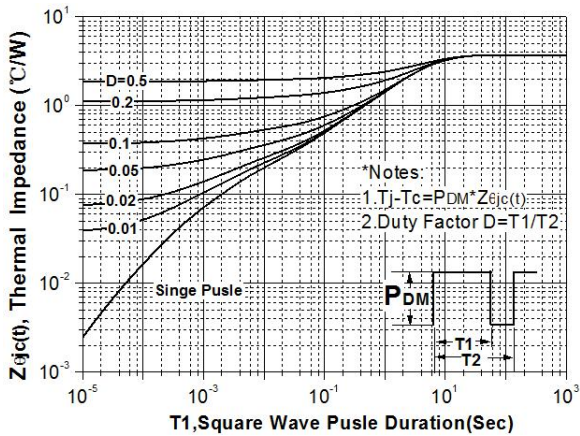
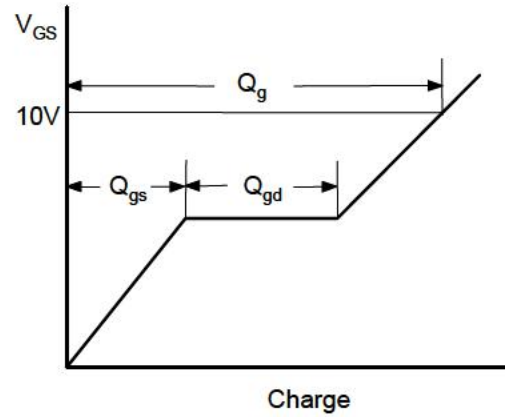
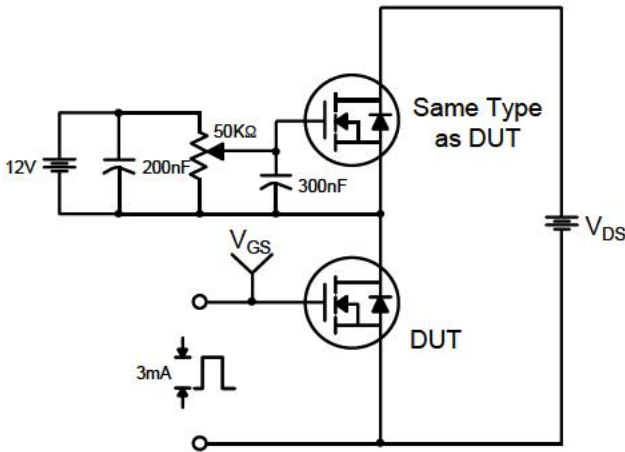

Figure 11. Transient Thermal Response Curve



### Gate Charge Test Circuit & Waveform



### Resistive Switching Test Circuit & Waveforms

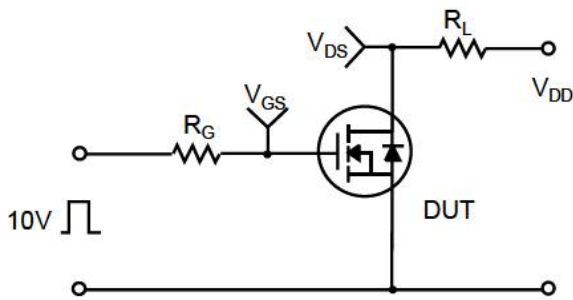

### Unclamped Inductive Switching Test Circuit & Waveforms

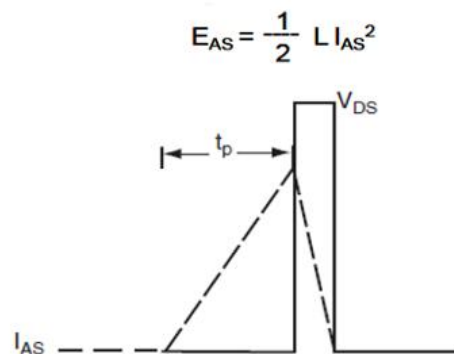
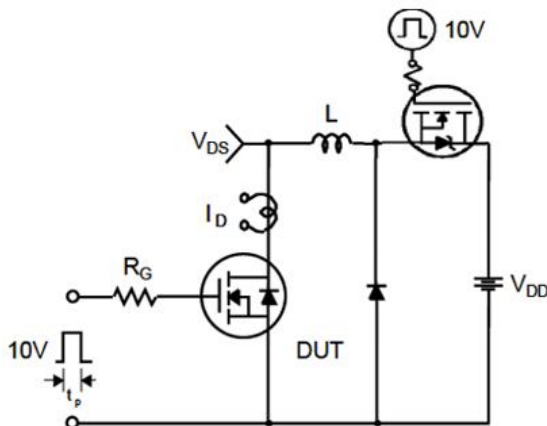



### Peak Diode Recovery dv/dt Test Circuit & Waveforms

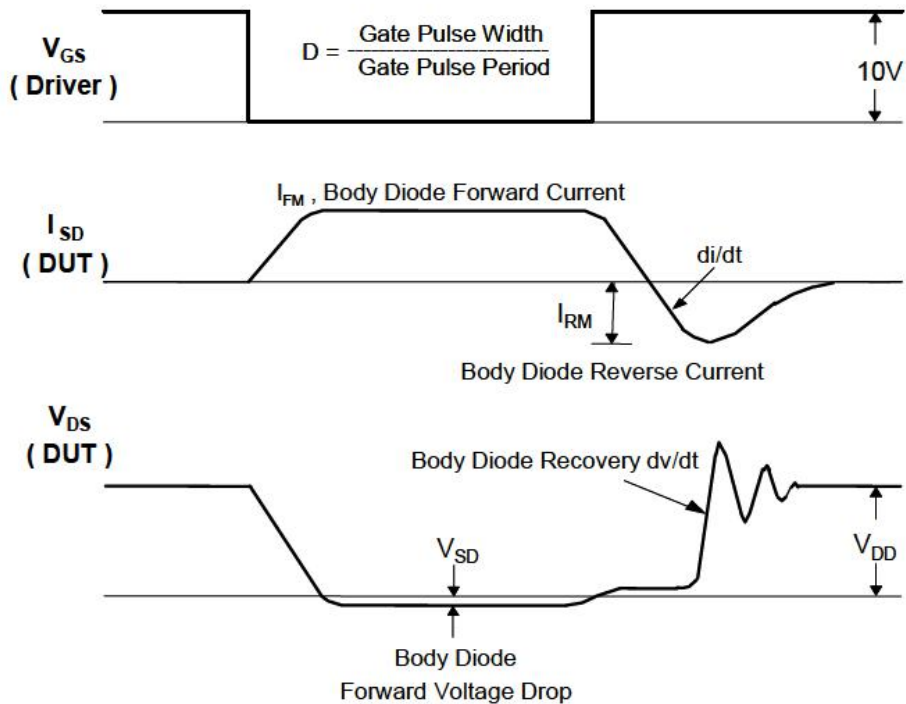
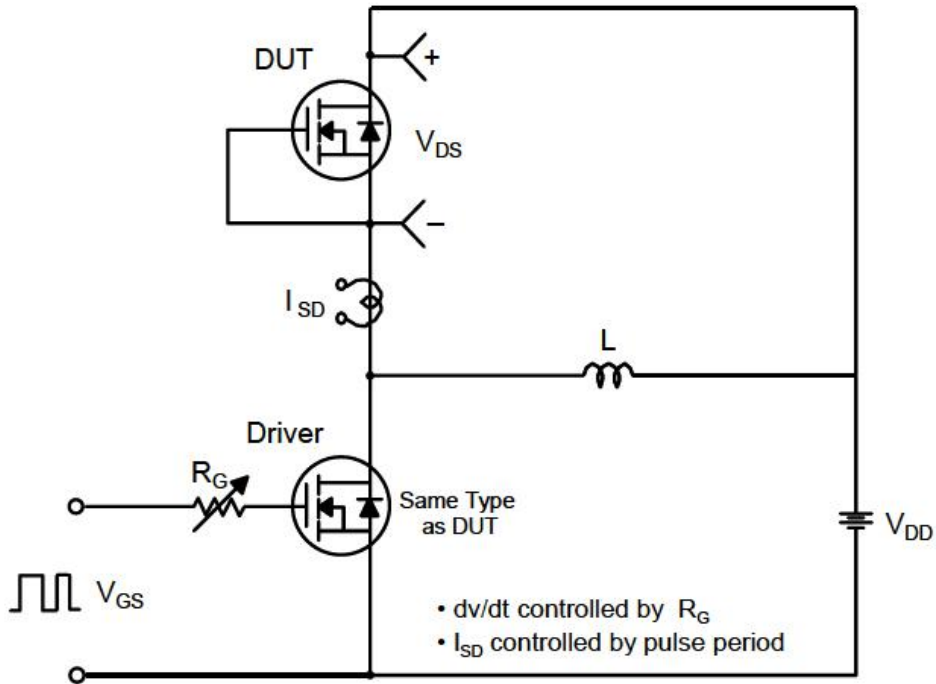





## Disclaimer

Brunei has made reasonable commercial efforts to ensure that the information given in this datasheet is correct. However, it must clearly be understood that such information is for guidance only and does not constitute any representation or form part of any offer or contract.

For documents and material available from this datasheet, Brunei does not warrant or assume any legal liability or responsibility for the accuracy, completeness, or usefulness of any information, product, technology or process disclosed hereunder.

Brunei reserves the rights to at its own discretion to make any changes or improvements to this datasheet. Unless said datasheet is incorporated into the formal contract, any customer should not rely on the information as any specification or product parameters duly committed by Brunei. Customers are hereby advised to verify that the information contained herein is current and complete before the entering of any contract or acknowledgement of any purchase order. Accordingly, all products specified hereunder shall be sold subject to Brunei's terms and conditions supplied at the time of order acknowledgement. Except where agreed upon by contractual agreement, testing of all parameters of each product is not necessarily performed.

Brunei does not warrant or convey any license either expressed or implied under its patent rights, nor the rights of others. Reproduction of information contained herein shall be only permissible if such reproduction is without any modification or alteration. Reproduction of this information with any alteration is an unfair and deceptive business practice. Brunei is not responsible or liable for such altered documentation.

Resale of Brunei's products with statements different from or beyond the parameters stated by Brunei for that product or service voids all express or implied warranties for the associated Brunei's product or service and is unfair and deceptive business practice. Brunei is not responsible or liable for any such statements.

Brunei's products are not authorized for use as critical components in life support devices or systems without the express written approval of Brunei. As used herein:

1. Life support devices or systems are devices or systems which, (a) are intended for surgical implant into the body, or (b) support or sustain life, and whose failure to perform, when properly used in accordance with instructions for use provided in the labeling, can be reasonably expected to result in a significant injury to the user.
2. A critical component is any component of a life support device or system whose failure to perform can be reasonably expected to cause the failure of the life support device or system, or to affect its safety or effectiveness.