

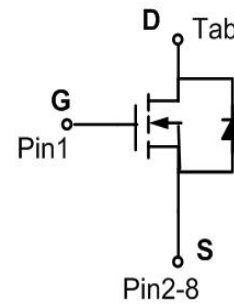

Description

These N-Channel enhancement mode power field effect transistors are using shielded gate trench DMOS technology. This advanced technology has been especially tailored to minimize on-state resistance, provide superior switching performance, and with stand high energy pulse in the avalanche and commutation mode. These devices are well suited for high efficiency fast switching applications.



N-Channel MOSFET

Features

- N-channel Power MOSFET
- Extremely low on-resistance $R_{DS(on)}$
- Excellent $Q_g \times R_{DS(on)}$ product(FOM)
- Qualified according to JEDEC criteria

Applications

- Motor control and drive
- Battery management
- UPS (Uninterruptible Power Supplies)
- DC-DC Converter

Pin Configuration

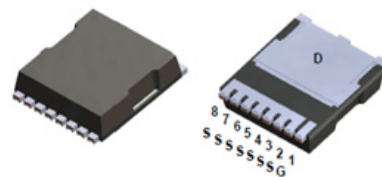

TOLL

Product Summary

V_{DSS}	100V
$R_{DS(on),typ} @V_{GS}=10V$	3.4m Ω
I_D	200A

Absolute Maximum Ratings $T_c = 25^\circ C$ unless otherwise noted

Parameter	Symbol	Value	Unit
Drain-Source Voltage	V_{DSS}	100	V
Continuous drain current ($T_c = 25^\circ C$) ($T_c = 100^\circ C$)	I_D	200 126	A A
Pulsed drain current ¹⁾	I_{DM}	796	A
Gate-Source voltage	V_{GSS}	± 20	V
Avalanche energy ²⁾	E_{AS}	702	mJ
Power Dissipation	P_D	278	W
Storage Temperature Range	T_{STG}	-55 to +150	$^\circ C$
Operating Junction Temperature Range	T_J	-55 to +150	$^\circ C$

Thermal Characteristics

Parameter	Symbol	Value	Unit
Thermal Resistance, Junction-to-Case	$R_{\theta JC}$	0.45	$^\circ C/W$
Thermal Resistance, Junction-to-Ambient ³⁾	$R_{\theta JA}$	50	$^\circ C/W$
Soldering temperature, wavesoldering only allowed at leads. (1.6mm from case for 10s)	T_{sold}	260	$^\circ C$



Package Marking and Ordering Information

Device	Device Package	Marking
WLE042R10	TOLL	WLE042R10

Electrical Characteristics

$T_J = 25^\circ\text{C}$ unless otherwise noted

Parameter	Symbol	Test Condition	Min.	Typ.	Max.	Unit
Static characteristics						
Drain-source breakdown voltage	BV_{DSS}	$V_{GS}=0\text{ V}, I_D=250\mu\text{A}$	100	---	---	V
Gate threshold voltage	$V_{GS(th)}$	$V_{DS}=V_{GS}, I_D=250\mu\text{A}$	2.0	---	4.0	V
Drain-source leakage current	I_{DSS}	$V_{DS}=100\text{ V}, V_{GS}=0\text{ V}, T_J = 25^\circ\text{C}$	---	---	1	μA
		$V_{DS}=100\text{ V}, V_{GS}=0\text{ V}, T_J = 150^\circ\text{C}$	---	---	10	mA
Gate leakage current, Forward	I_{GSSF}	$V_{GS}=20\text{ V}, V_{DS}=0\text{ V}$	---	---	100	nA
Gate leakage current, Reverse	I_{GSSR}	$V_{GS}=-20\text{ V}, V_{DS}=0\text{ V}$	---	---	-100	nA
Drain-source on-state resistance	$R_{DS(on)}$	$V_{GS}=10\text{ V}, I_D=50\text{ A},$ $T_J = 25^\circ\text{C}$	---	3.4	4.2	m Ω
		$T_J = 150^\circ\text{C}$	---	5.9	---	
Forward transconductance	g_{fs}	$V_{DS} = 5\text{ V}, I_D=50\text{ A}$	---	94	---	S
Dynamic characteristics						
Input capacitance	C_{iss}	$V_{DS} = 50\text{ V}, V_{GS} = 0\text{ V},$ $f = 250\text{kHz}$	---	7116	---	pF
Output capacitance	C_{oss}		---	1067	---	
Reverse transfer capacitance	C_{rss}		---	24	---	
Turn-on delay time	$t_{d(on)}$	$V_{DD} = 50\text{ V}, V_{GS}=10\text{V}, I_D = 50\text{ A}$	---	75	---	ns
Rise time	t_r		---	176	---	
Turn-off delay time	$t_{d(off)}$		---	110	---	
Fall time	t_f		---	66.7	---	
Gate resistance	R_g	$V_{GS}=0\text{V}, V_{DS}=0\text{V}, f=1\text{MHz}$	---	2.4	---	Ω
Gate charge characteristics						
Gate to source charge	Q_{gs}	$V_{DS}=80\text{V}, I_D = 50\text{A},$ $V_{GS}= 10\text{ V}$	---	28	---	nC
Gate to drain charge	Q_{gd}		---	33	---	
Gate charge total	Q_g		---	115	---	
Gate plateau voltage	$V_{plateau}$		---	5	---	V
Output Charge	Q_{oss}	$V_{DS}=80\text{ V}, V_{GS}= 0\text{V}$	---	160	---	nC
Drain-Source diode characteristics and Maximum Ratings						
Continuous Source Current	I_S		---	---	199	A
Pulsed Source Current	I_{SM}		---	---	796	A
Diode Forward Voltage	V_{SD}	$V_{GS}=0\text{V}, I_S=50\text{A}, T_J=25^\circ\text{C}$	---	---	1.1	V
Reverse Recovery Time	t_{rr}	$I_S=50\text{A}, di/dt=100\text{A}/\mu\text{s}, T_J=25^\circ\text{C}$	---	51	---	ns
Reverse Recovery Charge	Q_{rr}		---	56.8	---	nC

Notes:

- 1: Repetitive Rating: Pulse width limited by maximum junction temperature.
- 2: $V_{DD}=90\text{V}, V_{GS}=10\text{V}, L=0.5\text{mH}, I_{AS}=53\text{A}$, Starting $T_J=25^\circ\text{C}$.
- 3: The value of R_{thJA} is measured by placing the device in a still air box which is one cubic foot.



Electrical Characteristics Diagrams

Figure 1. Typ. Output Characteristics

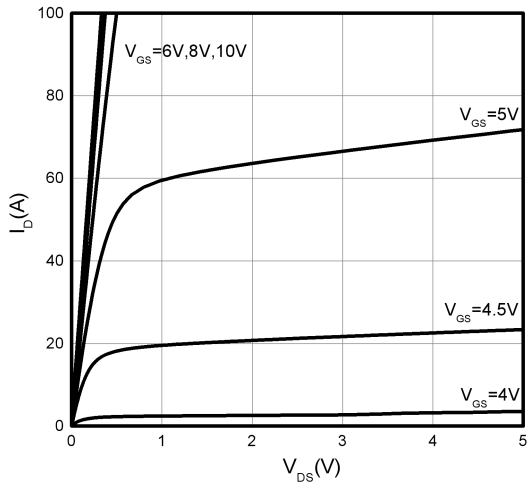

Figure 2. Transfer Characteristics

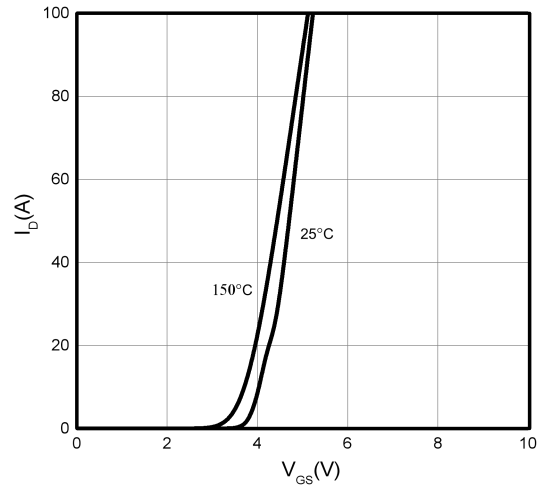

Figure 3. On-Resistance vs. Drain Current

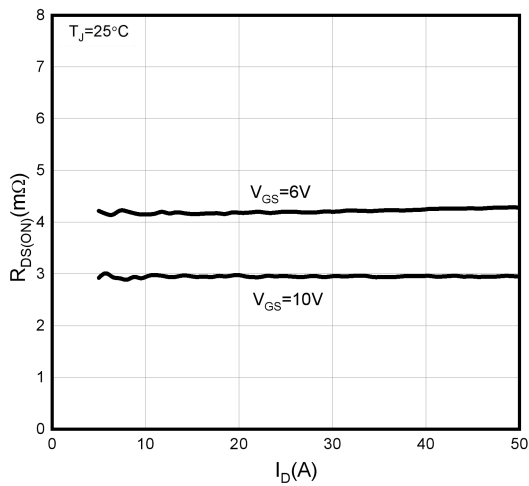

Figure 4. On-Resistance vs. Temperature

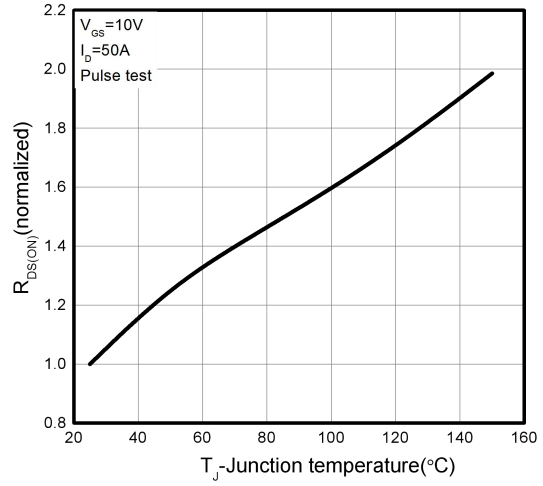

Figure 5. Breakdown Voltage vs. Temperature

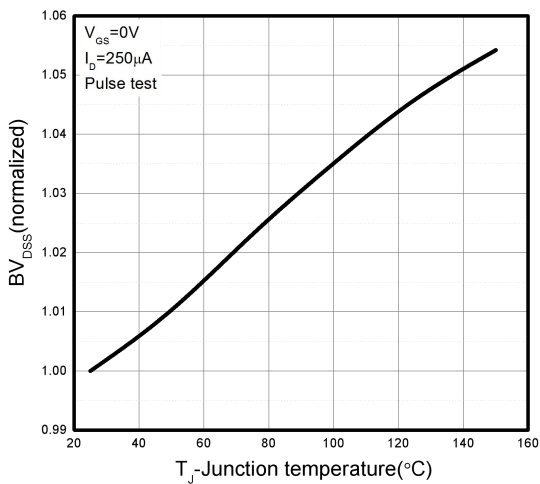

Figure 6. Threshold Voltage vs. Temperature

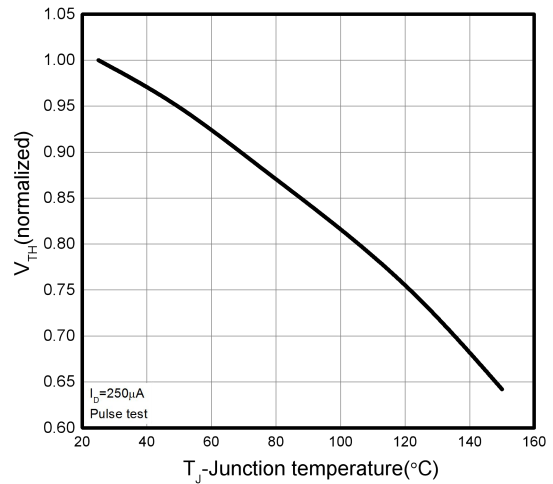



Figure 7. R_{DS(on)} vs. Gate Voltage

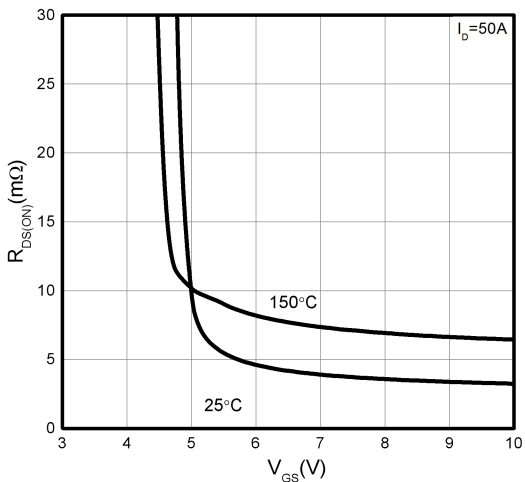

Figure 8. Body-Diode Characteristics

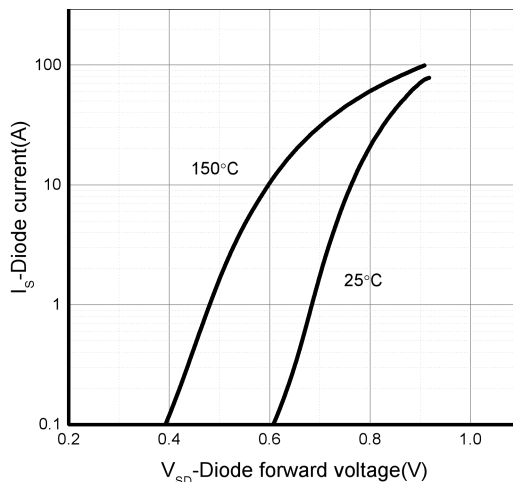

Figure 9. Capacitance Characteristics

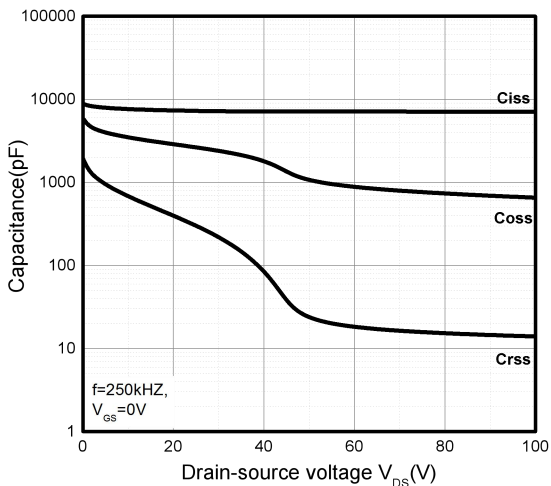

Figure 10. Gate Charge Characteristics

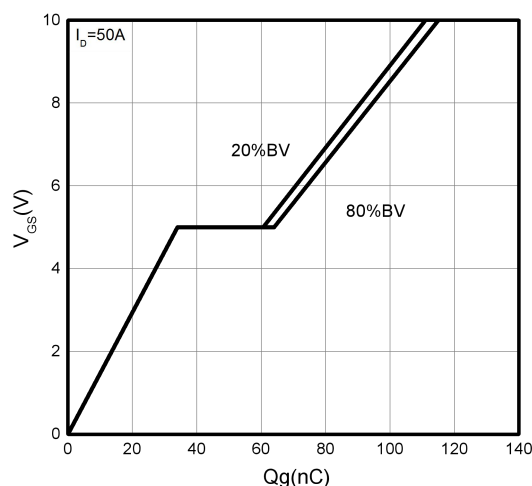

Figure 11. Drain Current Derating

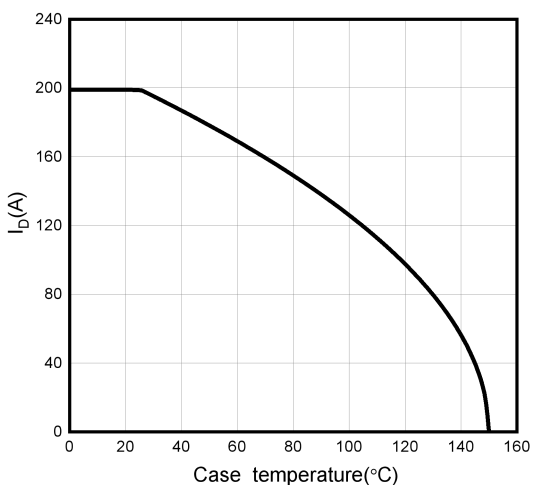

Figure 12. Power Dissipation vs. Temperature

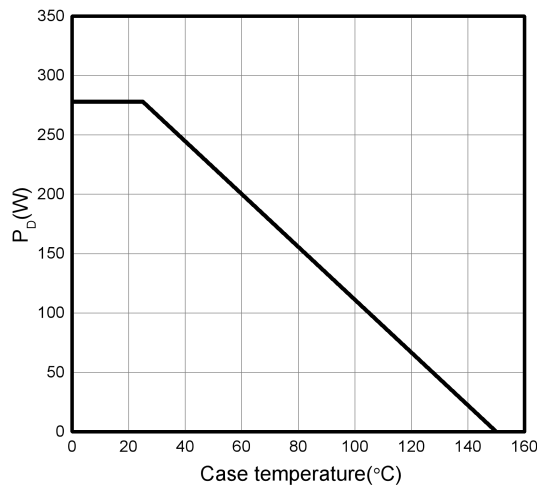



Figure 13. Safe Operating Area

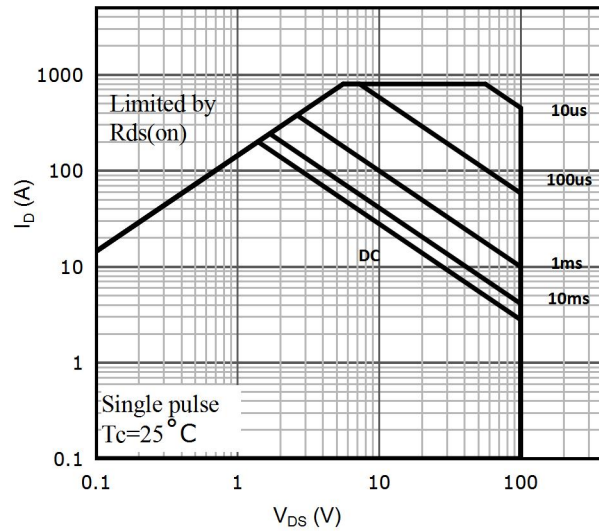
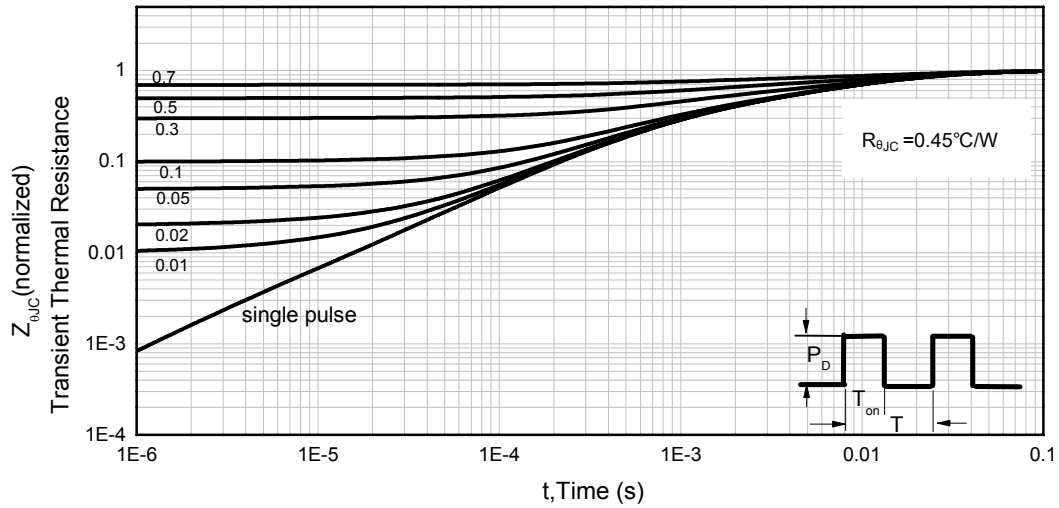

Figure 14. Normalized Maximum Transient Thermal Impedance (RthJC)





Test Circuit & Waveforms

Gate Charge Test Circuit & Waveform

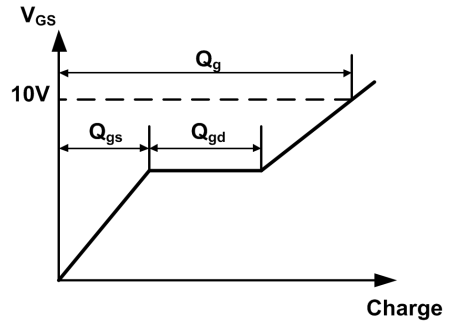
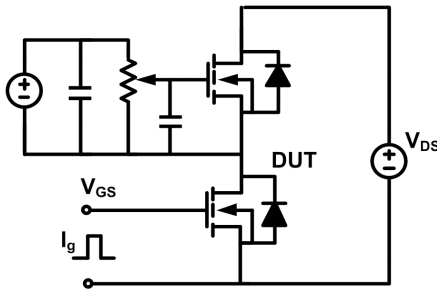

Resistive Switching Test Circuit & Waveform

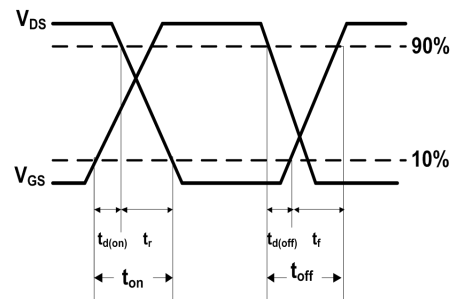
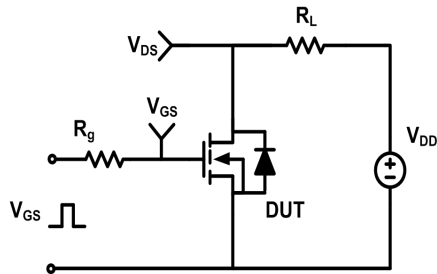

Unclamped Inductive Switching (UIS) Test Circuit & Waveform

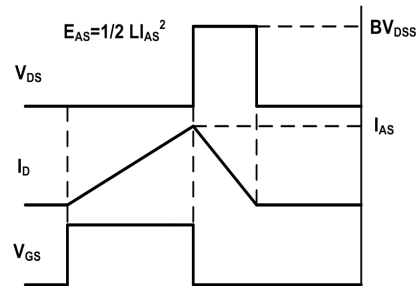
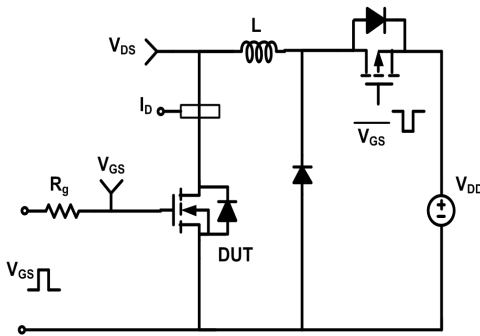

Diode Recovery Test Circuit & Waveform

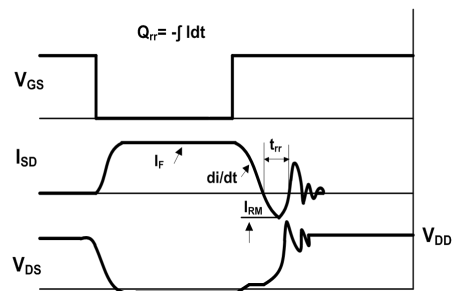
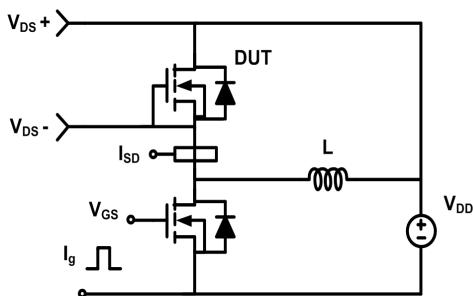



Mechanical Dimensions for TOLL

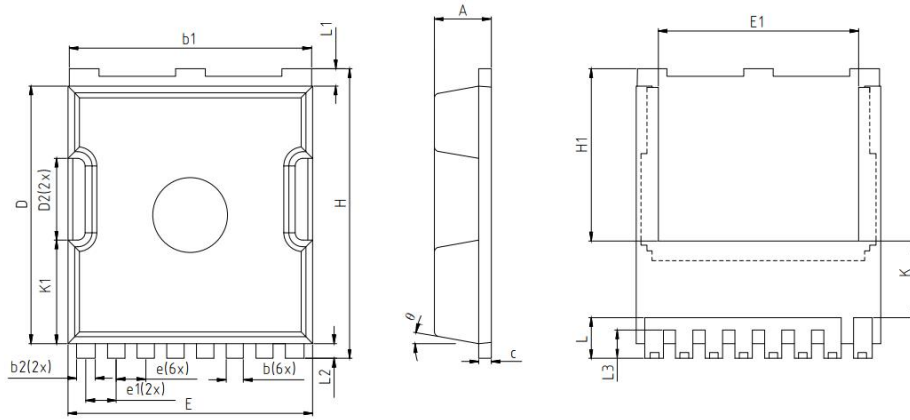

DIMENSIONS IN MILLIMETERS		
SYMBOL	MIN	MAX
A	2.20	2.40
b	0.60	0.80
b1	9.70	9.90
b2	0.65	0.85
c	0.40	0.60
D	10.28	10.58
D2	3.15	3.45
E	9.70	10.10
E1	7.90	8.30
e	1.20 BSC	
e1	1.225 BSC	
H	11.48	11.88
H1	6.95 BSC	
K	3.10 BSC	
K1	4.08	4.28
L	1.40	1.80
L1	0.60	0.80
L2	0.50	0.70
L3	1.00	1.30
θ	10° REF	



Disclaimer

Brunei has made reasonable commercial efforts to ensure that the information given in this datasheet is correct. However, it must clearly be understood that such information is for guidance only and does not constitute any representation or form part of any offer or contract.

For documents and material available from this datasheet, Brunei does not warrant or assume any legal liability or responsibility for the accuracy, completeness, or usefulness of any information, product, technology or process disclosed hereunder.

Brunei reserves the rights to at its own discretion to make any changes or improvements to this datasheet. Unless said datasheet is incorporated into the formal contract, any customer should not rely on the information as any specification or product parameters duly committed by Brunei Customers are hereby advised to verify that the information contained herein is current and complete before the entering of any contract or acknowledgement of any purchase order. Accordingly, all products specified hereunder shall be sold subject to Brunei's terms and conditions supplied at the time of order acknowledgement. Except where agreed upon by contractual agreement, testing of all parameters of each product is not necessarily performed.

Brunei does not warrant or convey any license either expressed or implied under its patent rights, nor the rights of others. Reproduction of information contained herein shall be only permissible if such reproduction is without any modification or alteration. Reproduction of this information with any alteration is an unfair and deceptive business practice. Brunei is not responsible or liable for such altered documentation.

Resale of Brunei's products with statements different from or beyond the parameters stated by Brunei for that product or service voids all express or implied warranties for the associated Brunei's product or service and is unfair and deceptive business practice. Brunei is not responsible or liable for any such statements.

Brunei's products are not authorized for use as critical components in life support devices or systems without the express written approval of Brunei. As used herein:

1. Life support devices or systems are devices or systems which, (a) are intended for surgical implant into the body, or (b) support or sustain life, and whose failure to perform, when properly used in accordance with instructions for use provided in the labeling, can be reasonably expected to result in a significant injury to the user.
2. A critical component is any component of a life support device or system whose failure to perform can be reasonably expected to cause the failure of the life support device or system, or to affect its safety or effectiveness.