



- ★ Super Low Gate Charge
- ★ 100% EAS Guaranteed
- ★ Green Device Available
- ★ Excellent CdV/dt effect decline
- ★ Advanced high cell density Trench technology

### Description

The WLU120N03 is the high cell density trenched N-ch MOSFETs, which provide excellent R<sub>DS(on)</sub> and gate charge for most of the synchronous buck converter applications.

The WLU120N03 meet the RoHS and Green Product requirement, 100% EAS guaranteed with full function reliability approved.

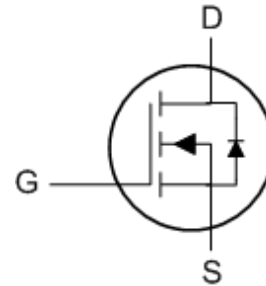

### TO252 Pin Configuration

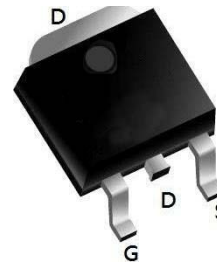

### Product Summary

BVDSS	R <sub>DS(on)</sub>	I <sub>D</sub>
30V	3.0mΩ	120 A

### Absolute Maximum Ratings

Symbol	Parameter	Rating		Units
		10s	Steady State	
V <sub>DS</sub>	Drain-Source Voltage	30		V
V <sub>GS</sub>	Gate-Source Voltage	±20		V
I <sub>D</sub> @T <sub>C</sub> =25°C	Continuous Drain Current, V <sub>GS</sub> @ 10V <sup>1</sup>	120		A
I <sub>D</sub> @T <sub>C</sub> =100°C	Continuous Drain Current, V <sub>GS</sub> @ 10V <sup>1</sup>	75		A
I <sub>DM</sub>	Pulsed Drain Current <sup>2</sup>	384		A
EAS	Single Pulse Avalanche Energy <sup>3</sup>	198		mJ
I <sub>AS</sub>	Avalanche Current	53.8		A
P <sub>D</sub> @T <sub>C</sub> =25°C	Total Power Dissipation <sup>4</sup>	62.5		W
P <sub>D</sub> @T <sub>A</sub> =25°C	Total Power Dissipation <sup>4</sup>	6	2.42	W
T <sub>STG</sub>	Storage Temperature Range	-55 to 175		°C
T <sub>J</sub>	Operating Junction Temperature Range	-55 to 175		°C

### Thermal Data

Symbol	Parameter	Typ.	Max.	Unit
R <sub>θJA</sub>	Thermal Resistance Junction-Ambient <sup>1</sup>	---	62	°C/W
R <sub>θJA</sub>	Thermal Resistance Junction-Ambient <sup>1</sup> (t ≤ 10s)	---	25	°C/W
R <sub>θJC</sub>	Thermal Resistance Junction-Case <sup>1</sup>	---	2.4	°C/W



### Electrical Characteristics (T<sub>J</sub>=25 °C, unless otherwise noted)

Symbol	Parameter	Test Conditions	Min.	Typ.	Max.	Unit
<b>Static Characteristics</b>						
BV <sub>DSS</sub>	Drain-Source Breakdown Voltage	V <sub>GS</sub> =0V, I <sub>DS</sub> =250μA	30	-	-	V
I <sub>DSS</sub>	Zero Gate Voltage Drain Current	V <sub>DS</sub> =24V, V <sub>GS</sub> =0V T <sub>J</sub> =85°C	-	-	1 30	μA
V <sub>GS(th)</sub>	Gate Threshold Voltage	V <sub>DS</sub> =V <sub>GS</sub> , I <sub>DS</sub> =250μA	1.4	1.7	2.5	V
I <sub>GSS</sub>	Gate Leakage Current	V <sub>GS</sub> =±20V, V <sub>DS</sub> =0V	-	-	±100	nA
R <sub>DS(ON)</sub> <sup>d</sup>	Drain-Source On-state Resistance	V <sub>GS</sub> =10V, I <sub>DS</sub> =20A T <sub>J</sub> =125°C	-	3.0 4.4	3.8 -	mΩ
		V <sub>GS</sub> =4.5V, I <sub>DS</sub> =15A	-	4.0	5.5	
Gfs	Forward Transconductance	V <sub>DS</sub> =5V, I <sub>DS</sub> =10A	-	24.6	-	S
<b>Diode Characteristics</b>						
V <sub>SD</sub> <sup>d</sup>	Diode Forward Voltage	I <sub>SD</sub> =20A, V <sub>GS</sub> =0V	-	0.8	1.1	V
t <sub>rr</sub>	Reverse Recovery Time	I <sub>DS</sub> =20A, di <sub>SD</sub> /dt=100A/μs	-	35.6	-	ns
t <sub>a</sub>	Charge Time		-	19.3	-	
t <sub>b</sub>	Discharge Time		-	16.3	-	
Q <sub>rr</sub>	Reverse Recovery Charge		-	26	-	
<b>Dynamic Characteristics</b> <sup>e</sup>						
R <sub>G</sub>	Gate Resistance	V <sub>GS</sub> =0V, V <sub>DS</sub> =0V, F=1MHz	-	1	2	Ω
C <sub>iss</sub>	Input Capacitance	V <sub>GS</sub> =0V, V <sub>DS</sub> =15V, Frequency=1.0MHz	-	2485	2971	pF
C <sub>oss</sub>	Output Capacitance		-	850	-	
C <sub>rss</sub>	Reverse Transfer Capacitance		-	85	-	
t <sub>d(ON)</sub>	Turn-on Delay Time	V <sub>DD</sub> =15V, R <sub>L</sub> =15Ω, I <sub>DS</sub> =1A, V <sub>GEN</sub> =10V, R <sub>G</sub> =6Ω	-	12.4	23	ns
t <sub>r</sub>	Turn-on Rise Time		-	9.5	18	
t <sub>d(OFF)</sub>	Turn-off Delay Time		-	27.2	49	
t <sub>f</sub>	Turn-off Fall Time		-	35.2	64	
<b>Gate Charge Characteristics</b> <sup>e</sup>						
Q <sub>g</sub>	Total Gate Charge	V <sub>DS</sub> =15V, V <sub>GS</sub> =10V, I <sub>DS</sub> =20A	-	20.6	28.8	nC
Q <sub>g</sub>	Total Gate Charge	V <sub>DS</sub> =15V, V <sub>GS</sub> =4.5V, I <sub>DS</sub> =20A	-	9.8	-	
Q <sub>gth</sub>	Threshold Gate Charge		-	1.8	-	
Q <sub>gs</sub>	Gate-Source Charge		-	3.8	-	
Q <sub>gd</sub>	Gate-Drain Charge		-	3.7	-	

Note d : Pulse test ; pulse width≤300μs, duty cycle≤2%.

Note e : Guaranteed by design, not subject to production testing.



### Typical Operating Characteristics

Power Dissipation

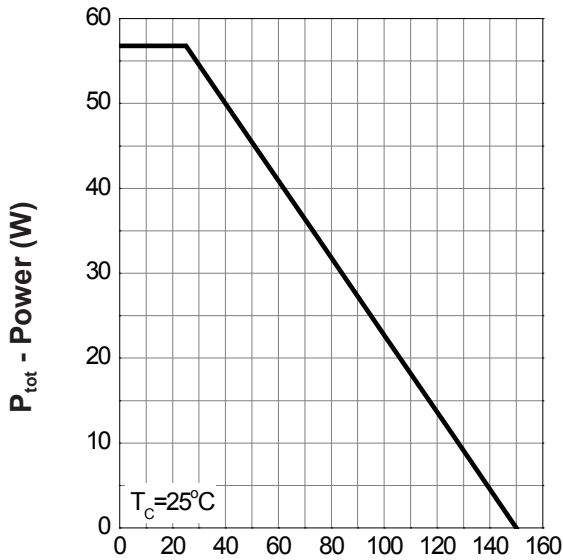

$T_j$  - Junction Temperature (°C)

Drain Current

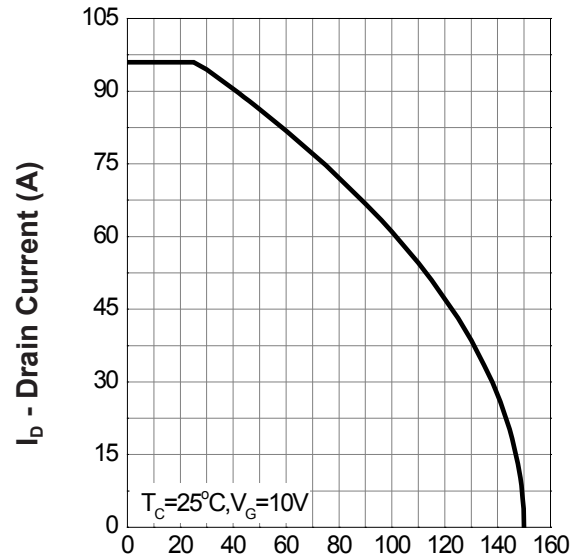

$T_j$  - Junction Temperature (°C)

Safe Operation Area

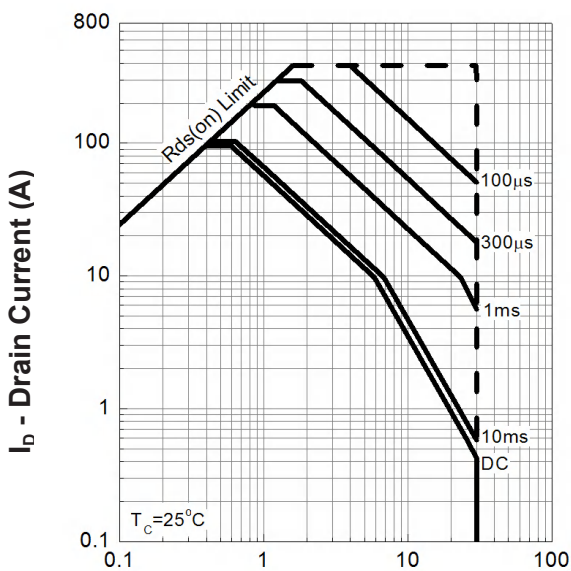

$V_{DS}$  - Drain - Source Voltage (V)

Thermal Transient Impedance

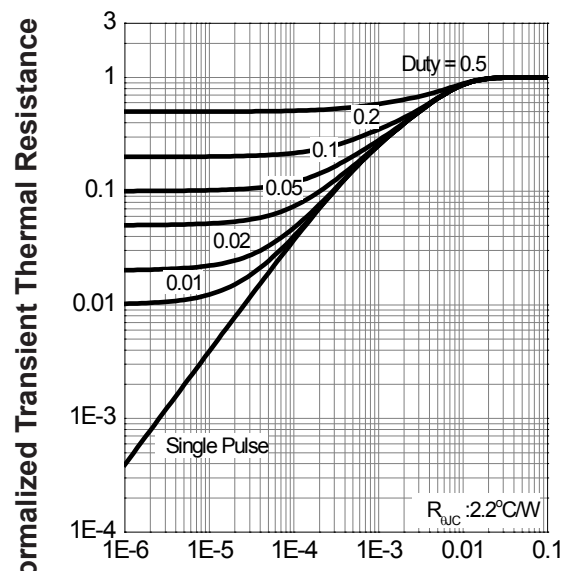

Square Wave Pulse Duration (sec)



### Typical Operating Characteristics(Cont.)

#### Safe Operation Area

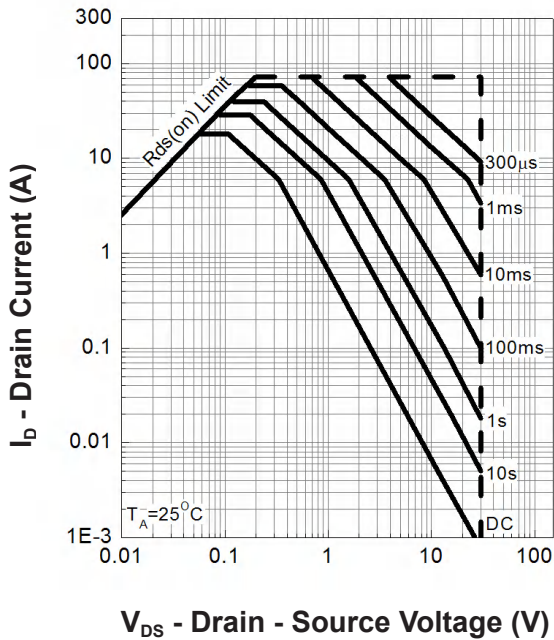

#### Thermal Transient Impedance

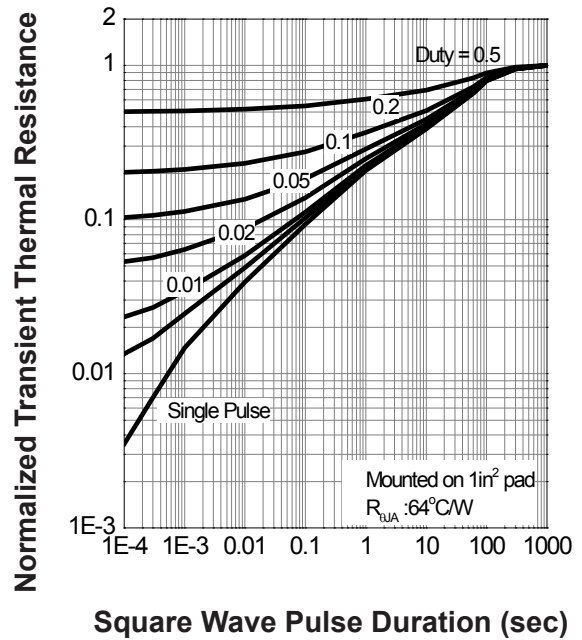

#### Output Characteristics

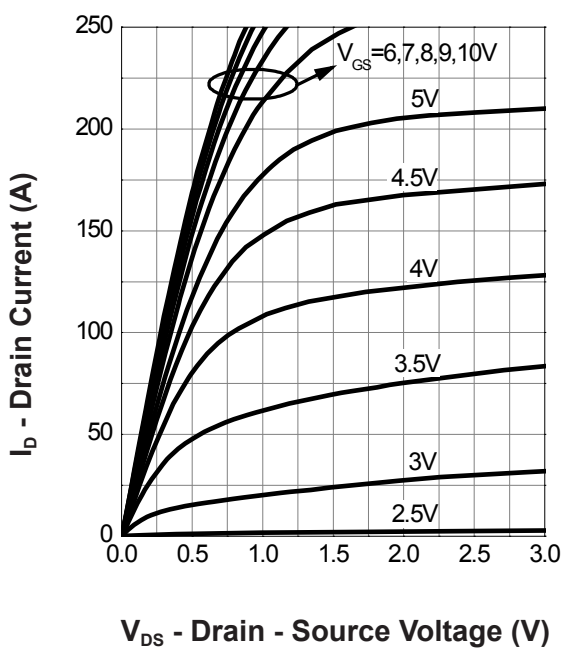

#### Drain-Source On Resistance

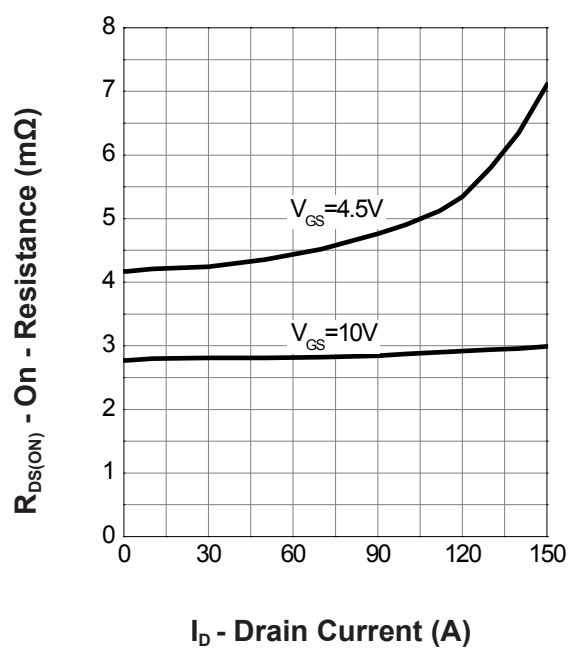



### Typical Operating Characteristics(Cont.)

Gate-Source On Resistance

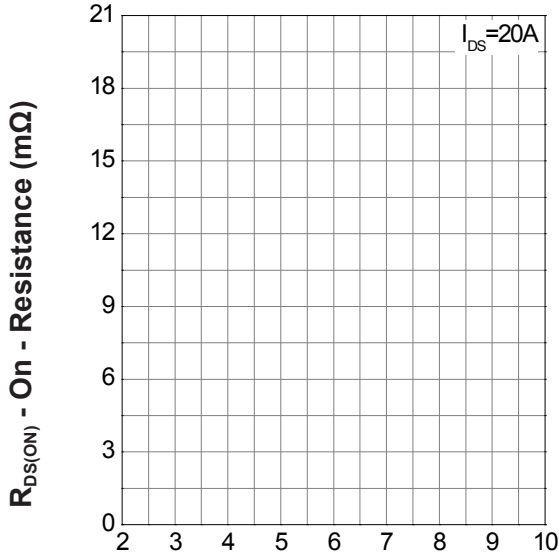

V<sub>GS</sub> - Gate - Source Voltage (V)

Gate Threshold Voltage

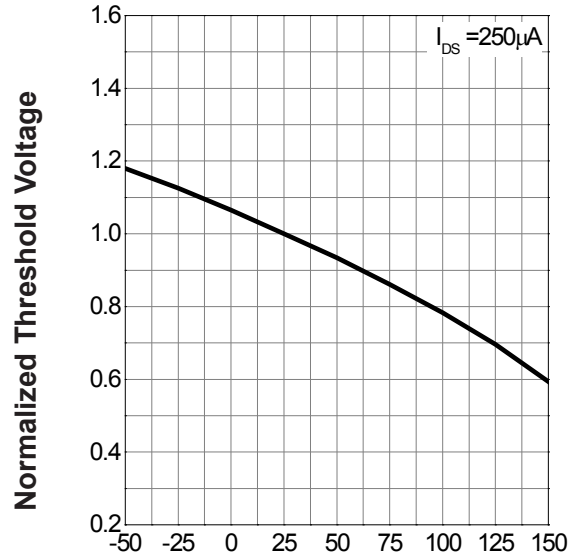

T<sub>J</sub> - Junction Temperature (°C)

Drain-Source On Resistance

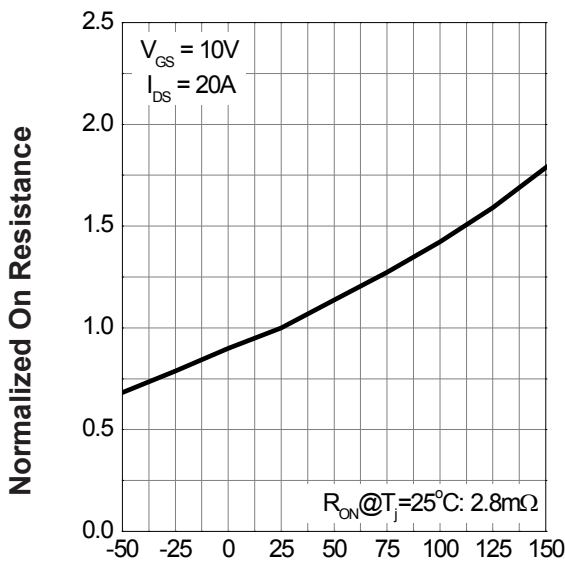

T<sub>J</sub> - Junction Temperature (°C)

Source-Drain Diode Forward

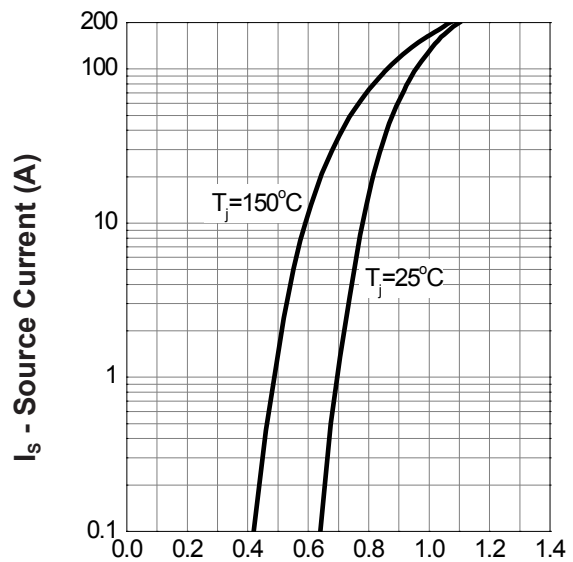

V<sub>SD</sub> - Source - Drain Voltage (V)



### Typical Operating Characteristics(Cont.)

Capacitance

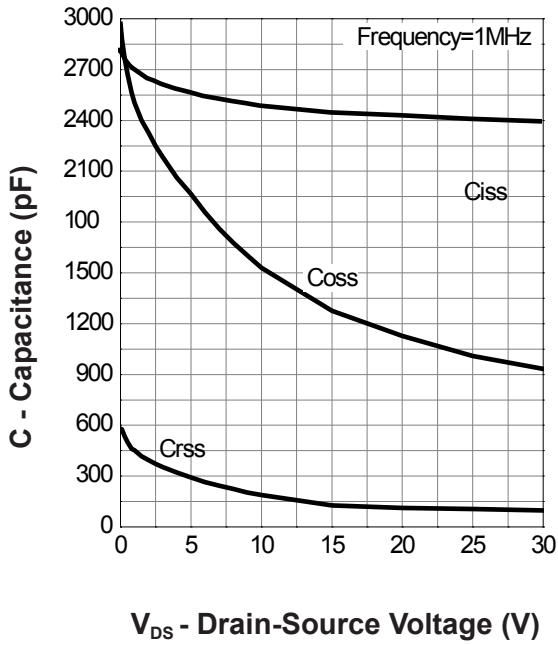

Gate Charge

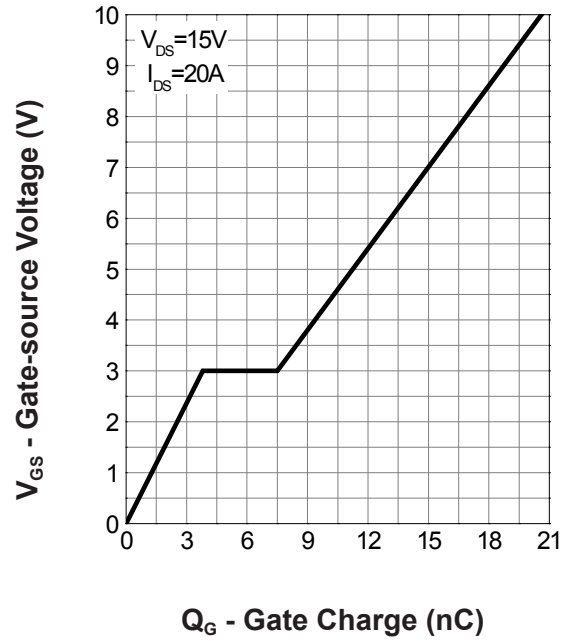



Package Mechanical Data TO 252

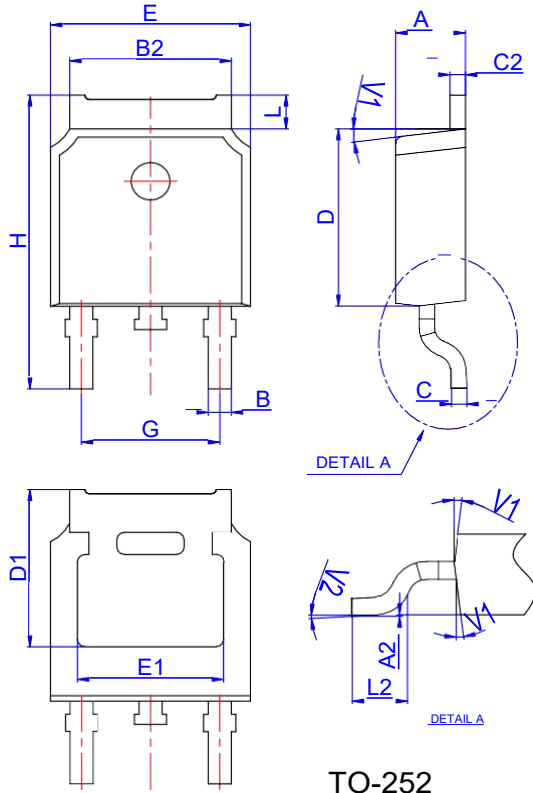

Ref.	Dimensions					
	Millimeters			Inches		
	Min.	Typ.	Max.	Min.	Typ.	Max.
A	2.10		2.50	0.083		0.098
A2	0		0.10	0		0.004
B	0.66		0.86	0.026		0.034
B2	5.18		5.48	0.202		0.216
C	0.40		0.60	0.016		0.024
C2	0.44		0.58	0.017		0.023
D	5.90		6.30	0.232		0.248
D1	5.30REF			0.209REF		
E	6.40		6.80	0.252		0.268
E1	4.63			0.182		
G	4.47		4.67	0.176		0.184
H	9.50		10.70	0.374		0.421
L	1.09		1.21	0.043		0.048
L2	1.35		1.65	0.053		0.065
V1		7°			7°	
V2	0°		6°	0°		6°

Reel Specification-TO-252-4R

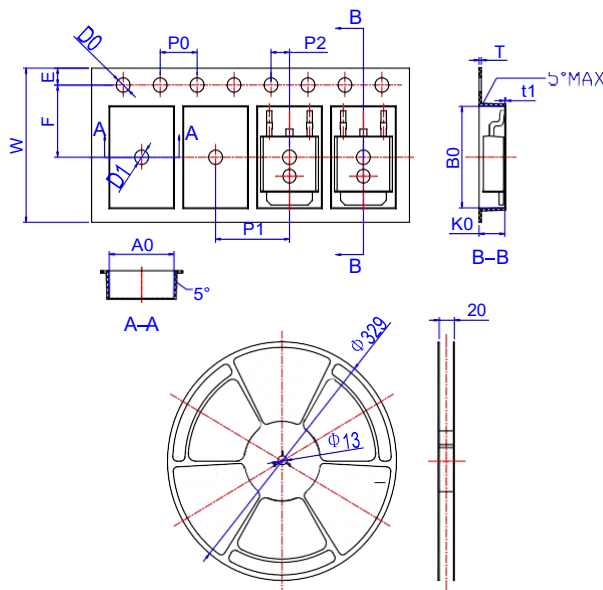

Ref.	Dimensions					
	Millimeters			Inches		
	Min.	Typ.	Max.	Min.	Typ.	Max.
W	15.90	16.00	16.10	0.626	0.630	0.634
E	1.65	1.75	1.85	0.065	0.069	0.073
F	7.40	7.50	7.60	0.291	0.295	0.299
D0	1.40	1.50	1.60	0.055	0.059	0.063
D1	1.40	1.50	1.60	0.055	0.059	0.063
P0	3.90	4.00	4.10	0.154	0.157	0.161
P1	7.90	8.00	8.10	0.311	0.315	0.319
P2	1.90	2.00	2.10	0.075	0.079	0.083
A0	6.85	6.90	7.00	0.270	0.271	0.276
B0	10.45	10.50	10.60	0.411	0.413	0.417
K0	2.68	2.78	2.88	0.105	0.109	0.113
T	0.24		0.27	0.009		0.011
t1	0.10			0.004		
10P0	39.80	40.00	40.20	1.567	1.575	1.583



## **Disclaimer**

Brunei has made reasonable commercial efforts to ensure that the information given in this datasheet is correct. However, it must clearly be understood that such information is for guidance only and does not constitute any representation or form part of any offer or contract.

For documents and material available from this datasheet, Brunei does not warrant or assume any legal liability or responsibility for the accuracy, completeness, or usefulness of any information, product, technology or process disclosed hereunder.

Brunei reserves the rights to at its own discretion to make any changes or improvements to this datasheet. Unless said datasheet is incorporated into the formal contract, any customer should not rely on the information as any specification or product parameters duly committed by Brunei Customers are hereby advised to verify that the information contained herein is current and complete before the entering of any contract or acknowledgement of any purchase order. Accordingly, all products specified hereunder shall be sold subject to Brunei's terms and conditions supplied at the time of order acknowledgement. Except where agreed upon by contractual agreement, testing of all parameters of each product is not necessarily performed.

Brunei does not warrant or convey any license either expressed or implied under its patent rights, nor the rights of others. Reproduction of information contained herein shall be only permissible if such reproduction is without any modification or alteration. Reproduction of this information with any alteration is an unfair and deceptive business practice. Brunei is not responsible or liable for such altered documentation.

Resale of Brunei's products with statements different from or beyond the parameters stated by Brunei for that product or service voids all express or implied warranties for the associated Brunei's product or service and is unfair and deceptive business practice. Brunei is not responsible or liable for any such statements.

Brunei's products are not authorized for use as critical components in life support devices or systems without the express written approval of Brunei. As used herein:

1. Life support devices or systems are devices or systems which, (a) are intended for surgical implant into the body, or (b) support or sustain life, and whose failure to perform, when properly used in accordance with instructions for use provided in the labeling, can be reasonably expected to result in a significant injury to the user.
2. A critical component is any component of a life support device or system whose failure to perform can be reasonably expected to cause the failure of the life support device or system, or to affect its safety or effectiveness.