

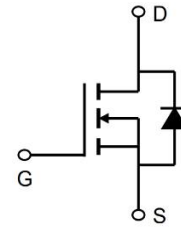

Description

The WLQ015R04F uses advanced technology to provide excellent $R_{DS(ON)}$, low gate charge and operation with gate voltages as low as 4.5V. This device is suitable for use as a Battery protection or in other Switching application.



General Features

$V_{DS} = 40V$ $I_D = 180A$

$R_{DS(ON)} < 1.5m\Omega$ @ $V_{GS}=10V$

Application

BMS

BLDC

UPS

PDFN5060-8L Pin Configuration

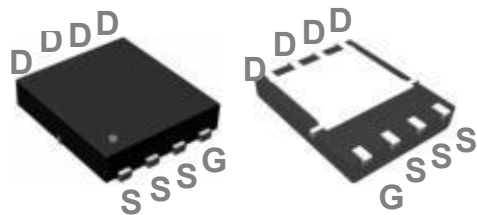

Package Marking and Ordering Information

Product ID	Pack	Marking	Qty(PCS)
WLQ015R04F	PDFN5*6-8L	WLQ015R04F XXX YYYY	5000

Absolute Maximum Ratings ($T_C=25^\circ C$ unless otherwise noted)

Symbol	Parameter	Max.	Units
V_{DS}	Drain-Source Voltage	40	V
V_{GS}	Gate-Source Voltage	± 20	V
$I_{D@TC=25^\circ C}$	Continuous Drain Current, $V_{GS} @ 10V_1$	180	A
$I_{D@TC=100^\circ C}$	Continuous Drain Current, $V_{GS} @ 10V_1$	125	A
I_{DM}	Pulsed Drain Current	750	A
E_{AS}	Single Pulsed Avalanche Energy	420	mJ
I_{AS}	Avalanche Current	70	A
$PD@TC=25^\circ C$	Power Dissipation	68	W
$R_{\theta JA}$	Thermal Resistance Junction-Ambient ¹	25	$^\circ C/W$
$R_{\theta JC}$	Thermal Resistance, Junction to Case	1.4	$^\circ C/W$
T_J	Operating Junction Temperature Range	-55 to 150	$^\circ C$
T_{STG}	Storage Temperature Range	-55 to 150	$^\circ C$



N-Channel Electrical Characteristics ($T_J=25^\circ\text{C}$, unless otherwise noted)

Symbol	Parameter	Test Condition	Min.	Typ.	Max.	Units
V(BR)DSS	Drain-Source Breakdown Voltage	$V_{GS}=0V, I_D=250\mu A$	40	48	-	V
IDSS	Zero Gate Voltage Drain Current	$V_{DS}=40V, V_{GS}=0V,$	-	-	1.0	μA
IGSS	Gate to Body Leakage Current	$V_{DS}=0V, V_{GS}= \pm 20V$	-	-	± 100	nA
VGS(th)	Gate Threshold Voltage	$V_{DS}=V_{GS}, I_D=250\mu A$	1.0	1.8	2.5	V
RDS(on)	Static Drain-Source on-Resistance	$V_{GS}=10V, I_D=30A$	-	1.15	1.5	m Ω
		$V_{GS}=4.5V, I_D=20A$	-	1.7	2.5	m Ω
Ciss	Input Capacitance	$V_{DS}=20V, V_{GS}=0V,$ $f=1.0MHz$	-	8300	-	pF
Coss	Output Capacitance		-	1510	-	pF
Crss	Reverse Transfer Capacitance		-	130	-	pF
Qg	Total Gate Charge	$V_{DS}=20V, I_D=85A,$ $V_{GS}=10V$	-	127	-	nC
Qgs	Gate-Source Charge		-	35	-	nC
Qgd	Gate-Drain("Miller") Charge		-	26	-	nC
td(on)	Turn-on Delay Time	$V_{DD}=20V, I_D=85A,$ $R_G=1.6\Omega, V_{GS}=10V$	-	22.5	-	ns
tr	Turn-on Rise Time		-	6.7	-	ns
td(off)	Turn-off Delay Time		-	80.3	-	ns
tf	Turn-off Fall Time		-	26.9	-	ns
IS	Maximum Continuous Drain to Source Diode Forward Current		-	-	185	A
ISM	Maximum Pulsed Drain to Source Diode Forward Current		-	-	750	A
VSD	Drain to Source Diode Forward Voltage	$V_{GS}=0V, I_S=30A$	-	-	1.2	V
trr	Body Diode Reverse Recovery Time	$T_J=25^\circ\text{C},$ $I_F=I_S, dI/dt=100A/\mu s$	-	100	-	ns
Qrr	Body Diode Reverse Recovery Charge		-	163	-	nC

Note :

- 1、 The data tested by surface mounted on a 1 inch 2 FR-4 board with 2OZ copper.
- 2、 The data tested by pulsed , pulse width $\leq 300\mu s$, duty cycle $\leq 2\%$
- 3、 The EAS data shows Max. rating . The test condition is $V_{DD}=32V, V_{GS}=10V, L=0.1mH, I_{AS}=70A$
- 4、 The power dissipation is limited by 150°C junction temperature
- 5、 The data is theoretically the same as I D and I DM , in real applications , should be limited by total power dissipation.



Typical Characteristics

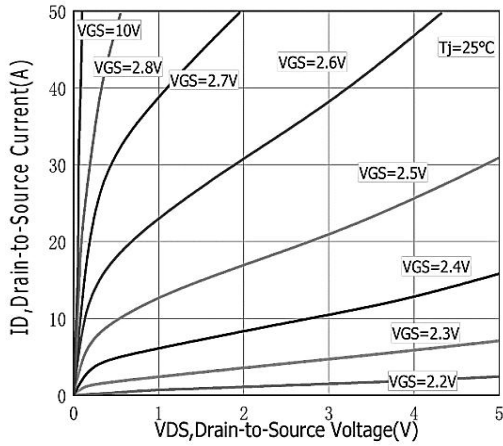

Figure 1: Typical Output Characteristics

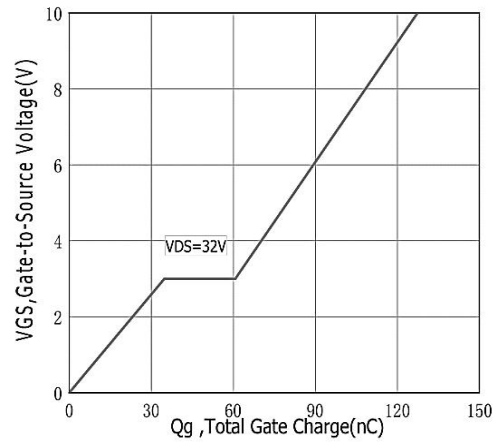

Figure 2: Typical Gate Charge vs Gate to Source Voltage

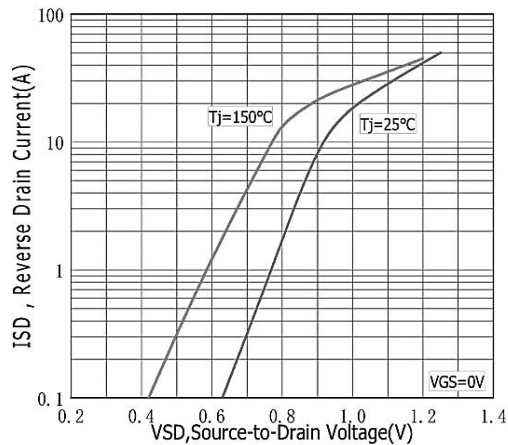

Figure 3: Typical Body Diode Transfer Characteristics

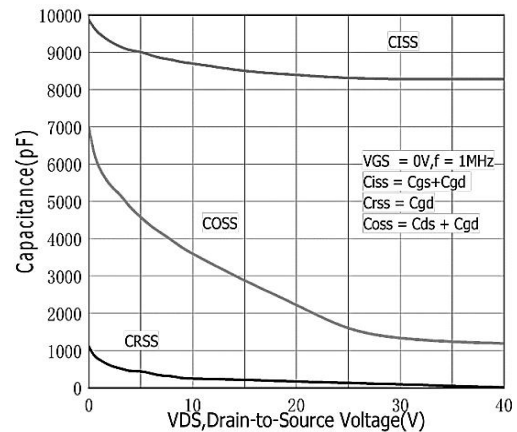

Figure 4: Typical Capacitance vs Drain to Source Voltage

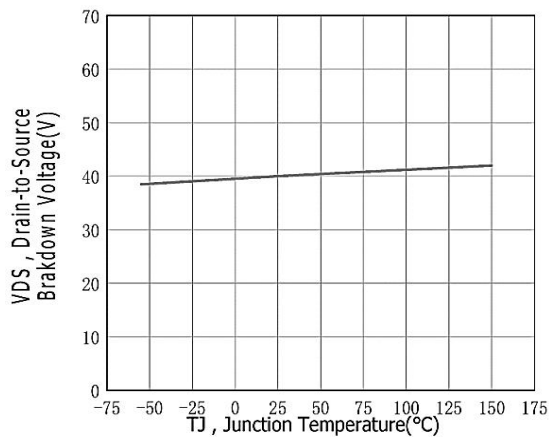

Figure 5: Typical Breakdown Voltage vs Junction Temperature

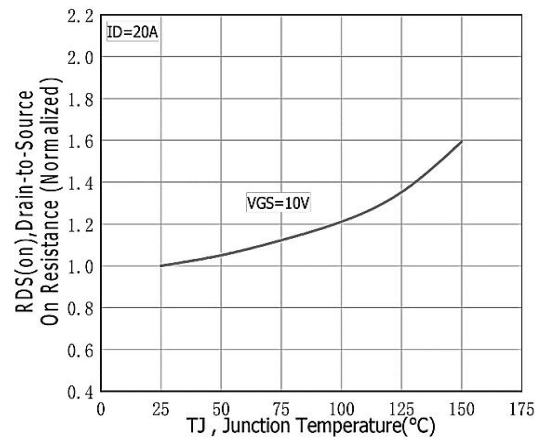

Figure 6: Typical Drain to Source on Resistance vs Junction Temperature

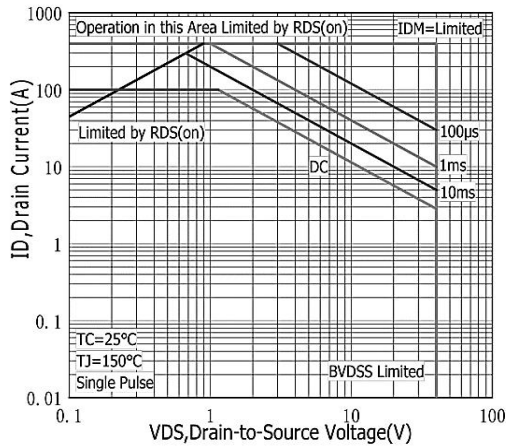

Figure 7: Maximum Forward Bias Safe Operating Area.

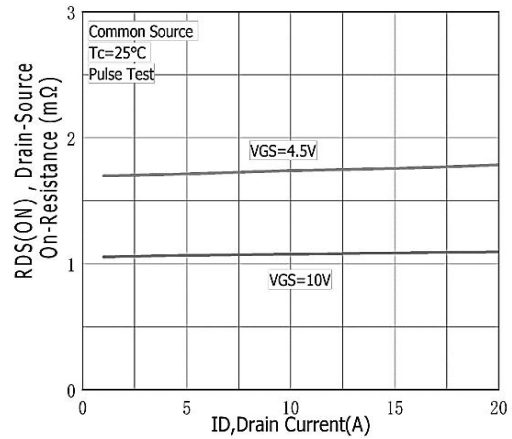

Figure 8: Typical Drain to Source ON Resistance vs Drain Current

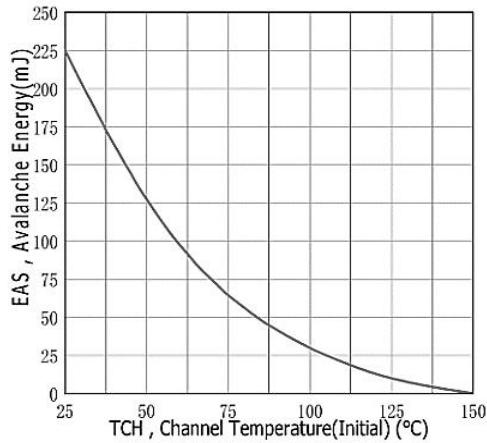

Figure 9: Maximum EAS vs Channel Temperature

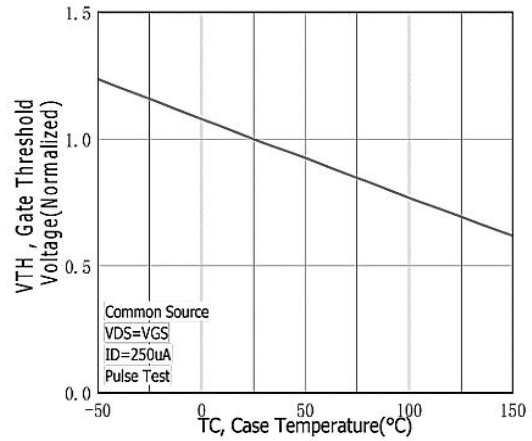

Figure 10: Typical Threshold Voltage vs Case Temperature

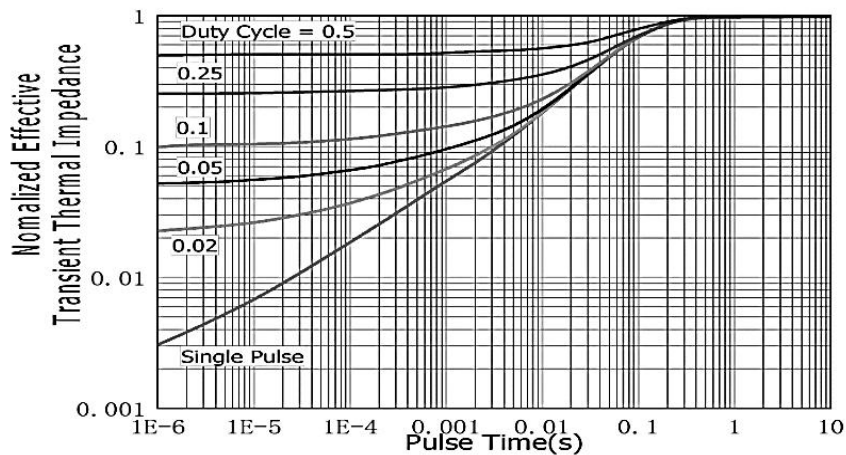
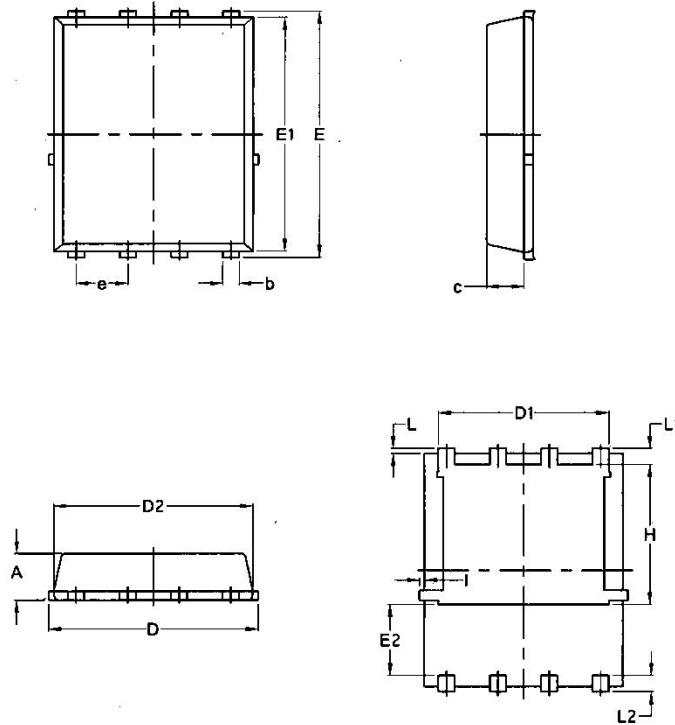

Figure.11: Maximum Effective Transient Thermal Impedance, Junction-to-Cas



Package Mechanical Data-PDFN5*6-8L-JQ Single



Symbol	Common			
	mm		Inch	
	Mim	Max	Min	Max
A	1.03	1.17	0.0406	0.0461
b	0.34	0.48	0.0134	0.0189
c	0.824	0.0970	0.0324	0.082
D	4.80	5.40	0.1890	0.2126
D1	4.11	4.31	0.1618	0.1697
D2	4.80	5.00	0.1890	0.1969
E	5.95	6.15	0.2343	0.2421
E1	5.65	5.85	0.2224	0.2303
E2	1.60	/	0.0630	/
e	1.27 BSC		0.05 BSC	
L	0.05	0.25	0.0020	0.0098
L1	0.38	0.50	0.0150	0.0197
L2	0.38	0.50	0.0150	0.0197
H	3.30	3.50	0.1299	0.1378
I	/	0.18	/	0.0070



Disclaimer

Brunei has made reasonable commercial efforts to ensure that the information given in this datasheet is correct. However, it must clearly be understood that such information is for guidance only and does not constitute any representation or form part of any offer or contract.

For documents and material available from this datasheet, Brunei does not warrant or assume any legal liability or responsibility for the accuracy, completeness, or usefulness of any information, product, technology or process disclosed hereunder.

Brunei reserves the rights to at its own discretion to make any changes or improvements to this datasheet. Unless said datasheet is incorporated into the formal contract, any customer should not rely on the information as any specification or product parameters duly committed by Brunei Customers are hereby advised to verify that the information contained herein is current and complete before the entering of any contract or acknowledgement of any purchase order. Accordingly, all products specified hereunder shall be sold subject to Brunei's terms and conditions supplied at the time of order acknowledgement. Except where agreed upon by contractual agreement, testing of all parameters of each product is not necessarily performed.

Brunei does not warrant or convey any license either expressed or implied under its patent rights, nor the rights of others. Reproduction of information contained herein shall be only permissible if such reproduction is without any modification or alteration. Reproduction of this information with any alteration is an unfair and deceptive business practice. Brunei is not responsible or liable for such altered documentation.

Resale of Brunei's products with statements different from or beyond the parameters stated by Brunei for that product or service voids all express or implied warranties for the associated Brunei's product or service and is unfair and deceptive business practice. Brunei is not responsible or liable for any such statements.

Brunei's products are not authorized for use as critical components in life support devices or systems without the express written approval of Brunei. As used herein:

1. Life support devices or systems are devices or systems which, (a) are intended for surgical implant into the body, or (b) support or sustain life, and whose failure to perform, when properly used in accordance with instructions for use provided in the labeling, can be reasonably expected to result in a significant injury to the user.
2. A critical component is any component of a life support device or system whose failure to perform can be reasonably expected to cause the failure of the life support device or system, or to affect its safety or effectiveness.