

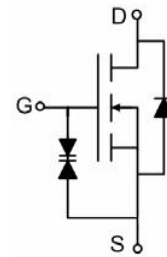

Features

- Low $R_{DS(on)}$ @ $V_{GS}=10V$
- 5V Logic Level Control
- N Channel SOT523 Package
- HMB ESD Protection 1KV
- Pb-Free, RoHS Compliant



Applications

- LED Lighting Application,
- ON/OFF switch
- Networking

SOT-523 Pin Configuration

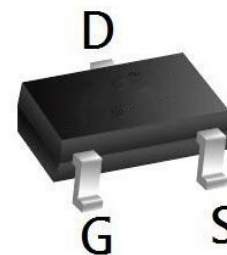

Product Summary

| BVDSS | RDSON | ID |
|-------|-------|------|
| 60V | 1.5mΩ | 0.5A |

Absolute Maximum Ratings ($T_A=25^\circ\text{C}$ unless otherwise specified)

| Symbol | Parameter | Rating | Unit | |
|--|---|--------------------------|--------------------|---|
| Common Ratings ($T_A=25^\circ\text{C}$ Unless Otherwise Noted) | | | | |
| V_{GS} | Gate-Source Voltage | ± 20 | V | |
| $V_{(BR)DSS}$ | Drain-Source Breakdown Voltage | 60 | V | |
| T_J | Maximum Junction Temperature | 150 | $^\circ\text{C}$ | |
| T_{STG} | Storage Temperature Range | -50 to 150 | $^\circ\text{C}$ | |
| Mounted on Large Heat Sink | | | | |
| I_{DM} | Pulse Drain Current Tested① | $T_A = 25^\circ\text{C}$ | 0.8 | A |
| I_D | Continuous Drain Current($V_{GS}=4.5V$) | $T_A = 25^\circ\text{C}$ | 0.3 | A |
| | | $T_A = 70^\circ\text{C}$ | 0.24 | |
| P_D | Maximum Power Dissipation | $T_A = 25^\circ\text{C}$ | 0.9 | W |
| | | $T_A = 70^\circ\text{C}$ | 0.6 | |
| $R_{\theta JA}$ | Thermal Resistance Junction-Ambient | 125 | $^\circ\text{C/W}$ | |



Electrical Characteristics (T_J=25°C unless otherwise specified)

| Symbol | Parame | Condition | Min | Typ | Max | Unit |
|--|--|---|-----|------|------|------|
| Static Electrical Characteristics @ T_J = 25°C (unless otherwise stated) | | | | | | |
| V _{(BR)DSS} | Drain-Source Breakdown Voltage | V _{GS} =0V I _D =250μA | 60 | -- | -- | V |
| I _{DSS} | Zero Gate Voltage Drain Current(T _A =25°C) | V _{DS} =60V, V _{GS} =0V | -- | -- | 1 | μA |
| | Zero Gate Voltage Drain Current(T _A =125°C) | V _{DS} =60V, V _{GS} =0V | -- | -- | 100 | uA |
| I _{GSS} | Gate-Body Leakage Current | V _{GS} =±12V, V _{DS} =0V | -- | -- | ±100 | nA |
| V _{GS(TH)} | Gate Threshold Voltage | V _{DS} =V _{GS} , I _D =250μA | 1.0 | 1.5 | 2.5 | V |
| R _{DS(ON)} | Drain-Source On-State Resistance② | V _{GS} =10V, I _D =0.3A | -- | 1.5 | 3 | Ω |
| R _{DS(ON)} | Drain-Source On-State Resistance② | V _{GS} =4.5V, I _D =0.2A | -- | 2.6 | 6 | Ω |
| Dynamic Electrical Characteristics @ T_J = 25°C (unless otherwise stated) | | | | | | |
| C _{iss} | Input Capacitance | V _{DS} =30V, V _{GS} =0V, f=1MHz | -- | 1 | | pF |
| C _{oss} | Output Capacitance | | -- | 3 | -- | pF |
| C _{rss} | Reverse Transfer Capacitance | | -- | 0 | -- | pF |
| Q _g | Total Gate Charge | V _{DS} =30V I _D =0.3A, V _{GS} =4.5V | -- | 0.5 | -- | nC |
| Q _{gs} | Gate Source Charge | | -- | 0.12 | -- | nC |
| Q _{gd} | Gate Drain Charge | | -- | 0.21 | -- | nC |
| Switching Characteristics | | | | | | |
| t _{d(on)} | Turn on Delay Time | V _{DD} =30V, I _D =0.3A, R _G =3.3Ω, V _{GS} =10V | -- | 4.5 | -- | n |
| t _r | Turn on Rise Time | | -- | 3.1 | -- | n |
| t _{d(off)} | Turn Off Delay Time | | - | 15 | -- | n |
| t _f | Turn Off Fall Time | | -- | 3.3 | -- | n |
| Source Drain Diode Characteristics | | | | | | |
| I _{SD} | Source drain current(Body Diode) | T _A =25°C | -- | - | 0.2 | A |
| V _{SD} | Forward on voltage② | T _J =25°C, I _{SD} =0.2A, V _{GS} =0V | -- | 0 | 1.2 | V |

Notes:

① Pulse width limited by maximum allowable junction temperature

② Pulse test ; Pulse width≤300μs, duty cycle≤2%.



Typical Characteristics

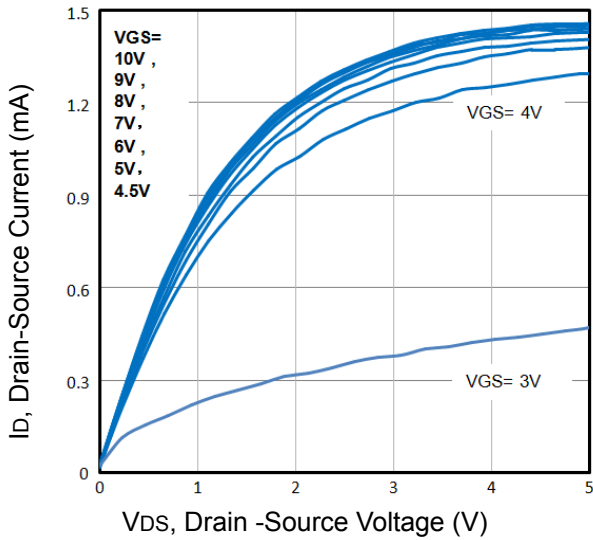

Fig1. Typical Output Characteristics

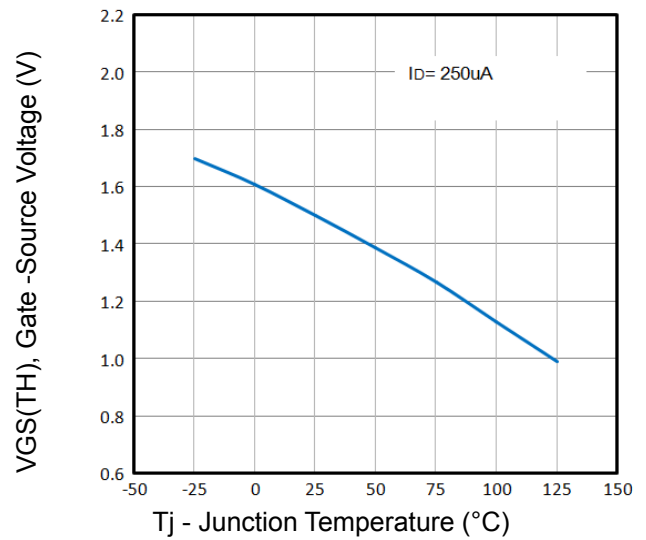

Fig2. Normalized Threshold Voltage Vs. Temperature

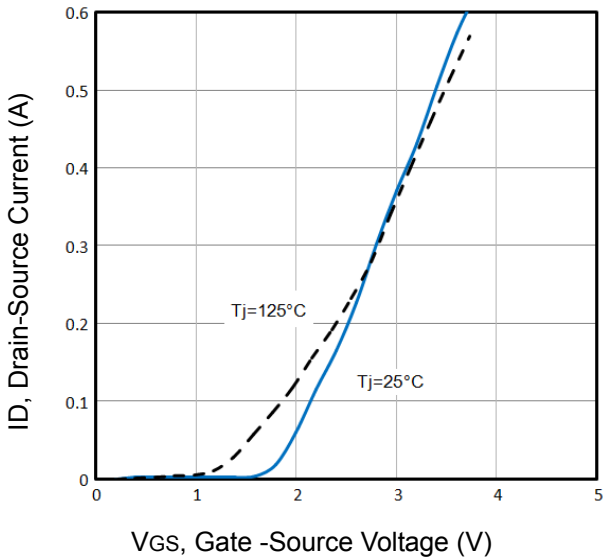

Fig3. Typical Transfer Characteristics

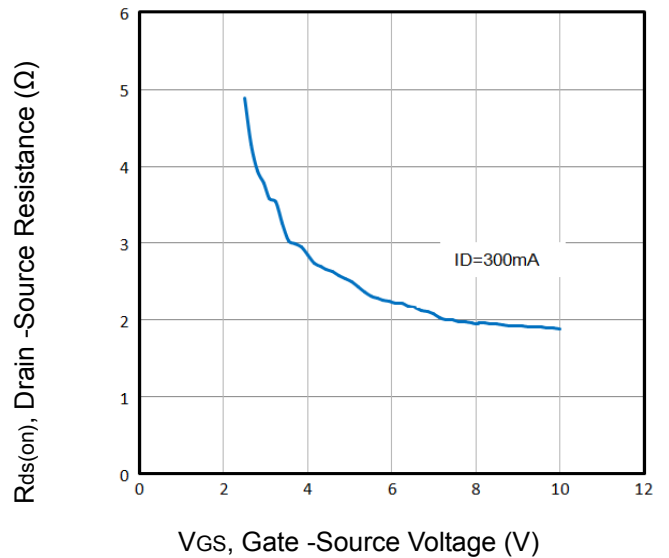

Fig4. Rds(on) vs Gate-Source Voltage

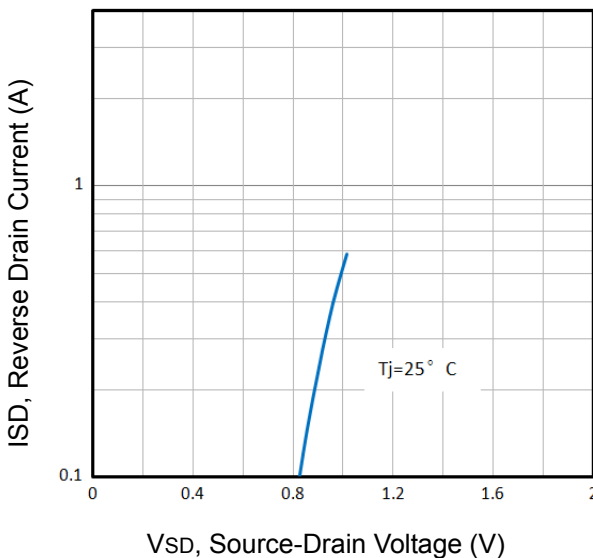

Fig5. Typical Source-Drain Diode Forward Voltage

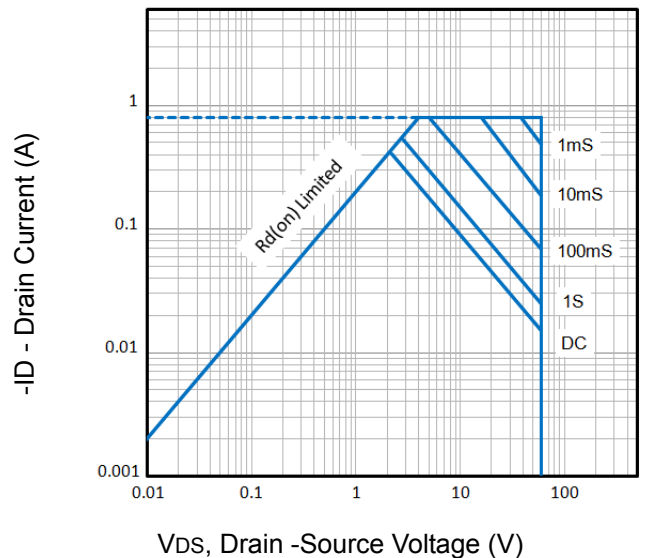

Fig6. Maximum Safe Operating Area



Typical Characteristics

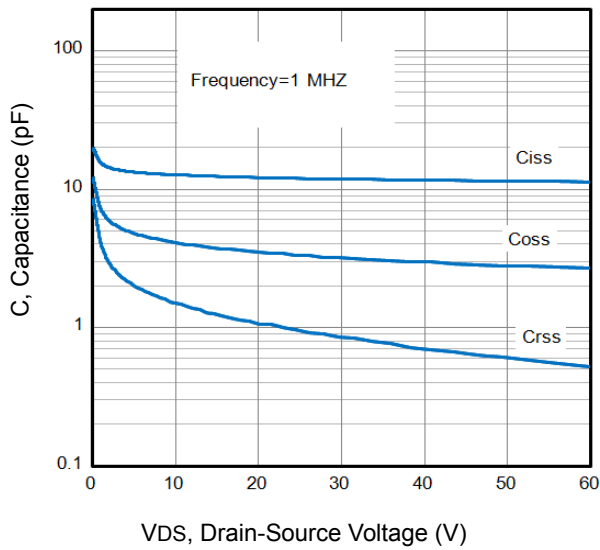

Fig7. Typical Capacitance Vs. Drain-Source Voltage

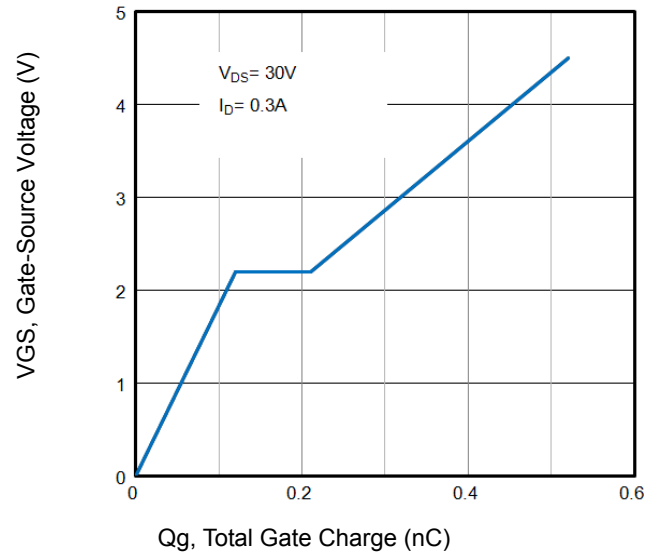

Fig8. Typical Gate Charge Vs. Gate-Source Voltage

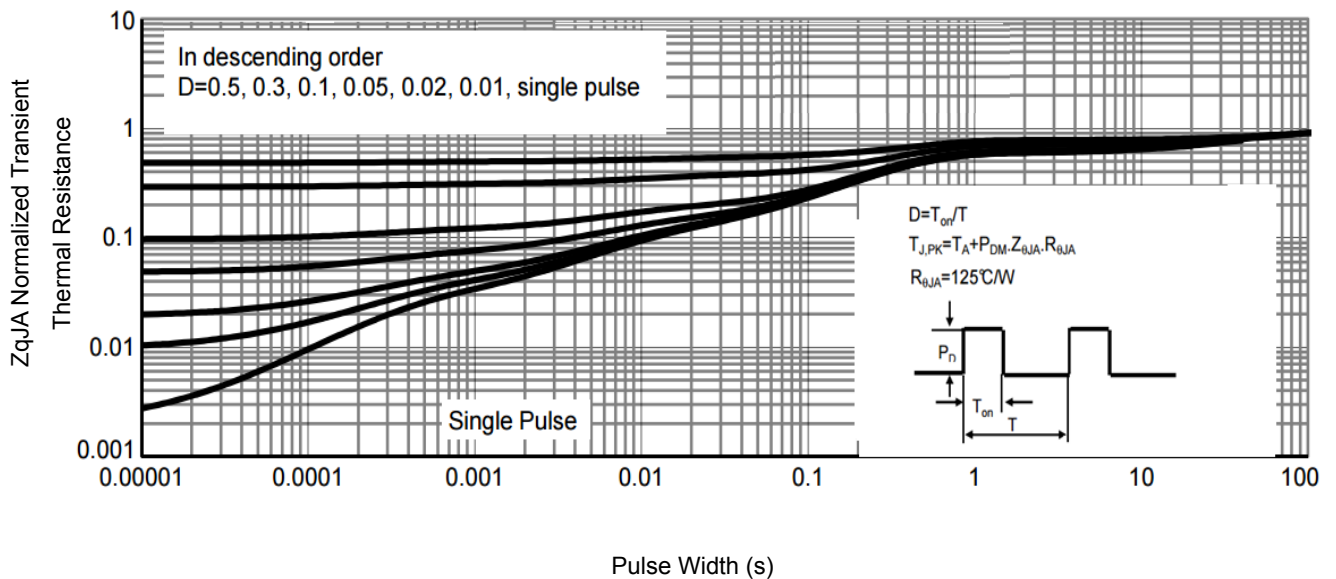

Fig9. Normalized Maximum Transient Thermal Impedance

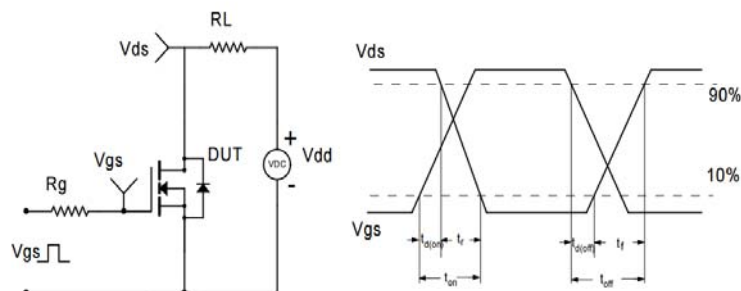
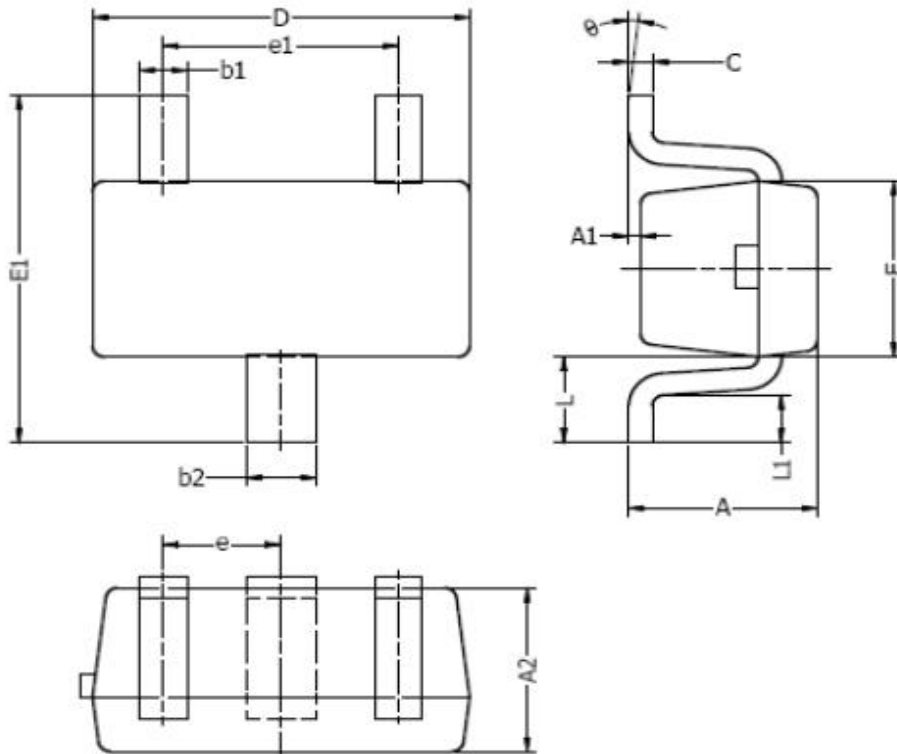

Fig10. Switching Time Test Circuit and waveforms



Package Mechanical Data-SOT-523-3L



| DIM | MILLIMETERS | | INCHES | |
|-------|-------------|------|------------|-------|
| | MIN | MAX | MIN | MAX |
| A | 0.70 | 0.90 | 0.028 | 0.035 |
| A1 | 0.00 | 0.10 | 0.000 | 0.004 |
| A2 | 0.70 | 0.80 | 0.028 | 0.031 |
| b1 | 0.15 | 0.25 | 0.006 | 0.010 |
| b2 | 0.25 | 0.35 | 0.010 | 0.014 |
| c | 0.10 | 0.20 | 0.004 | 0.008 |
| D | 1.50 | 1.70 | 0.059 | 0.067 |
| E | 0.70 | 0.90 | 0.028 | 0.035 |
| E1 | 1.45 | 1.75 | 0.057 | 0.069 |
| e | 0.50 TYP. | | 0.020 TYP. | |
| e1 | 0.90 | 1.10 | 0.035 | 0.043 |
| L | 0.40 REF. | | 0.016 REF. | |
| L1 | 0.10 | 0.30 | 0.004 | 0.012 |
| theta | 0° | 8° | 0° | 8° |

NOTES:
 1. Above package outline conforms to JEITA EAJ ED-7500A SC-75A.
 2. Dimensions are exclusive of Burrs, Mold Flash & Tie Bar extrusions.



Disclaimer

Brunei has made reasonable commercial efforts to ensure that the information given in this datasheet is correct. However, it must clearly be understood that such information is for guidance only and does not constitute any representation or form part of any offer or contract.

For documents and material available from this datasheet, Brunei does not warrant or assume any legal liability or responsibility for the accuracy, completeness, or usefulness of any information, product, technology or process disclosed hereunder.

Brunei reserves the rights to at its own discretion to make any changes or improvements to this datasheet. Unless said datasheet is incorporated into the formal contract, any customer should not rely on the information as any specification or product parameters duly committed by Brunei Customers are hereby advised to verify that the information contained herein is current and complete before the entering of any contract or acknowledgement of any purchase order. Accordingly, all products specified hereunder shall be sold subject to Brunei's terms and conditions supplied at the time of order acknowledgement. Except where agreed upon by contractual agreement, testing of all parameters of each product is not necessarily performed.

Brunei does not warrant or convey any license either expressed or implied under its patent rights, nor the rights of others. Reproduction of information contained herein shall be only permissible if such reproduction is without any modification or alteration. Reproduction of this information with any alteration is an unfair and deceptive business practice. Brunei is not responsible or liable for such altered documentation.

Resale of Brunei's products with statements different from or beyond the parameters stated by Brunei for that product or service voids all express or implied warranties for the associated Brunei's product or service and is unfair and deceptive business practice. Brunei is not responsible or liable for any such statements.

Brunei's products are not authorized for use as critical components in life support devices or systems without the express written approval of Brunei. As used herein:

1. Life support devices or systems are devices or systems which, (a) are intended for surgical implant into the body, or (b) support or sustain life, and whose failure to perform, when properly used in accordance with instructions for use provided in the labeling, can be reasonably expected to result in a significant injury to the user.
2. A critical component is any component of a life support device or system whose failure to perform can be reasonably expected to cause the failure of the life support device or system, or to affect its safety or effectiveness.